

Basic functional neuroanatomy

J. A. Kiernan
Department of Anatomy and Cell Biology
The University of Western Ontario
London, Canada

Address for correspondence:

Dr J. A. Kiernan
Department of Anatomy and Cell Biology
Medical Sciences Building
The University of Western Ontario
LONDON, Canada N6A 5C1

Copyright © J. A. Kiernan, 2005, 2009

The nervous system is used by everyone to feel, move and think, to experience every symptom and to communicate with every physician. It is a remarkably resilient system, but its importance to the body's economy is so great that the effects of disease can be devastating.

Importance of neuroanatomy for diagnosis

Some diseases simultaneously affect many parts of the central or peripheral nervous system, causing such symptoms as a reduced level of consciousness, mental impairment, or multiple motor or sensory deficits. Other disorders are due to circumscribed lesions, which include vascular occlusions, localized infections, some tumours, and the changes brought about by some injuries. When neurological symptoms and signs result from a circumscribed lesion, an accurate diagnosis may often be made on the basis of the physician's knowledge of the normal anatomy and connectivity of the nervous system. There are two approaches to the analysis of a clinical problem when involvement of the nervous system is suspected:

1. Functions attributed to a particular part of the brain or spinal cord are found to be disordered, thereby indicating the site of an irritating or a destructive lesion. In many cases the functions of these regions have been deduced principally from correlation of clinical conditions with pathological findings, either after death or in images of the living brain. Many disorders affecting the cerebral hemispheres and the cerebellum are diagnosed in this way, working from the assumption that particular functions are carried out in localized regions of the central nervous system.

2. The clinical features point to interruption of a functional pathway (usually motor or sensory, but sometimes associated with other functions such as memory or speech). Diseases of the spinal cord are evaluated in this way, and so are some lesions in the brain stem and cerebrum, and disorders affecting individual peripheral nerves, roots or ganglia. Clinicopathological correlations have contributed importantly to knowledge of the functional anatomy of the peripheral nervous system and to discovery of the dispositions of sensory, motor and other pathways in the human spinal cord and brain.

Imaging techniques such as computer-assisted tomography, angiography and nuclear magnetic resonance imaging, contribute importantly to diagnosis, and the neuroradiologist needs a detailed working knowledge of the topographical anatomy of the brain in order to interpret the images. Here, however, we are concerned with the neuroanatomy needed for clinical diagnosis. Functions of the nervous system are considered first regionally and then in terms of pathways, which are systems of connected neurons that serve particular purposes.

Some definitions.

The interactions of larger parts of the nervous system are understandable only in terms of the activities of large numbers of individual cells. The definitions presented in **Table 1** will remind

the reader of (a) the terminology of Neuroscience relating to communication within and among cells, and (b) the words used to specify parts of the nervous system on a larger scale.

TABLE 1. Some neuroanatomical terminology.

This list of definitions is presented in logical rather than alphabetical order. The little things (cells and their parts) are followed by bigger things (words used for tissues and larger anatomical objects).

Cellular components

A **neuron** is a cell specialized for communication with other cells. It typically has a cell-body containing the nucleus and other common organelles, and one or more long extensions of the cytoplasm: the dendrites and the axon.

A **neurite** is any cytoplasmic process of a neuron: a dendrite or an axon.

An **axon** is a cytoplasmic extension of uniform diameter that conducts action potentials or (also called impulses), which are the most rapidly neuronal signals. A neuron has only one axon; it branches terminally and may also have collateral branches nearer to the cell-body.

A **myelin sheath** is a multi-layered membranous formation that intimately invests many types of axon, allowing action potentials to propagate much more rapidly than they can in unmyelinated axons. Myelin accounts for the pale color of white matter in the brain.

A **nerve fiber** is an axon together with its myelin sheath (if present) and associated neuroglial cells.

A **dendrite** is a cytoplasmic process that is widest at its union with the neuronal cell body and becomes narrower with increased length and repeated branching. Dendrites increase the surface area of the cell to accommodate numerous afferent synaptic terminals. The signals that move along a dendrite are graded variations in the electrical potential difference across the cell membrane; they propagate more slowly than the

impulses that travel along an axon.

A **synapse** is a site of functional contact between cytoplasmic processes of neurons (*e.g.* a branch of an axon with a branch of a dendrite) or between a terminal branch of an axon and a cell that is not a neuron (*e.g.* a muscle fiber). A chemical **neurotransmitter** is released by the presynaptic neurite and acts on a **receptor** on the postsynaptic neurite. Changes in the receptor and tend to excite or inhibit the postsynaptic cell. At any time the activity or inactivity of the postsynaptic cell is determined by summation of its excitatory and inhibitory synaptic inputs.

Receptor. This word has two meanings. *At the cellular level* it is a molecule that responds to a chemical signal, such as a synaptic transmitter. *On a larger scale*, a receptor is a sense organ, which may be large (as is the eye) or small (as are terminal branches of axons in the skin).

A **neuroglial** or **glial** cell is a cell in the nervous system that is not a neuron. They outnumber the neurons 10:1 and have several well understood functions. The **Schwann cell** is the typical peripheral glial cell; it surrounds axons and recognizes their need for myelination. Central glia include **astrocytes**, **oligodendrocytes** and **microglia**. The glial cells in a nerve, which intimately invest the axons, are called **Schwann cells**; these occur also in ganglia, along with **satellite cells** associated with the neuronal cell bodies. Neuroglial cells have a variety of important functions.

Anatomical terms

Gray matter is central nervous tissue that contains neuronal cell bodies. Dendrites, axons and synapses are also present in gray matter.

A **nucleus** is a circumscribed region of gray matter, often named from its location, appearance or function.

A **ganglion** is, strictly speaking, a collection of neuronal cell bodies in the peripheral nervous system: the sensory ganglia of the dorsal spinal roots and of some cranial nerves, and the sympathetic, parasympathetic and enteric ganglia that innervate smooth and cardiac muscle and secretory cells. In the central nervous system, certain large nuclei of the forebrain and upper brain stem are called the basal ganglia¹, and the cells in the retina whose axons enter the optic nerve are known as ganglion cells. (The retina and optic nerve are parts of the central nervous system.)

White matter is central nervous tissue that is largely composed of myelinated axons. These fibers are organized into fasciculi, capsules, peduncles and tracts.

A **sulcus** is a groove; a **gyrus** is a convexity, delimited by sulci.

A **fasciculus** is any bundle of nerve fibers, central or peripheral.

A **capsule** is a large, flattened region of white matter.

A **peduncle** (the word means "stalk") is a stout bundle of white matter that physically as well as functionally joins two major parts of the brain together.

A **tract** is a region of the central nervous system largely occupied by a population of axons that all have the same origin and destination, which often form the name. For example, the spinothalamic tract consists of the axons of neurons whose cell bodies are in the spinal cord, and the fibers of this tract end in the thalamus.

A **root** is a bundle of axons, with associated supporting cells and connective tissue, that traverses the subarachnoid space. A dorsal (sensory) and a ventral (motor) **spinal root** join, at each intervertebral foramen, to form a mixed **spinal nerve**. Cranial nerves

also have roots, but these are usually named as nerves.

A **nerve** is a bundle of axons, with associated supporting cells and connective tissue, that is not a root and is outside the central-peripheral nervous system boundary. The optic nerve is badly named because it is an outgrowth of the brain, as is the retina.

A **ramus** is a branch (Latin) of a nerve. The **communicating rami** (*rami communicantes*) carry axons between spinal nerves and sympathetic ganglia.

A **pathway** is a set of interconnected groups of neurons that serves a particular function. For example, the visual pathway, which conducts signals from the retina to the cerebral cortex, is composed of various nuclei and tracts.

Afferent means carrying towards, whereas **efferent** means carrying away from. These terms are relative. For example, the motor fibers in a nerve are efferents of the spinal cord and afferent to muscles.

Rostral means "higher" (literally, towards the beak), and **caudal** means "lower" (towards the tail). When describing levels of the central nervous system, these adjectives are preferred to the "superior" and "inferior" of ordinary human anatomical terminology.

¹ The anatomically correct term **basal nuclei** is used by some scientists and clinicians, but "basal ganglia" is used here because it is the more commonly encountered expression.

Development of the nervous system.

The neural tube.

The neurons and neuroglial cells are derived from the **ectoderm** of the embryo, the layer that also gives rise to the epidermis. The **neural plate**, a thickening of the ectoderm, is evident 16 days

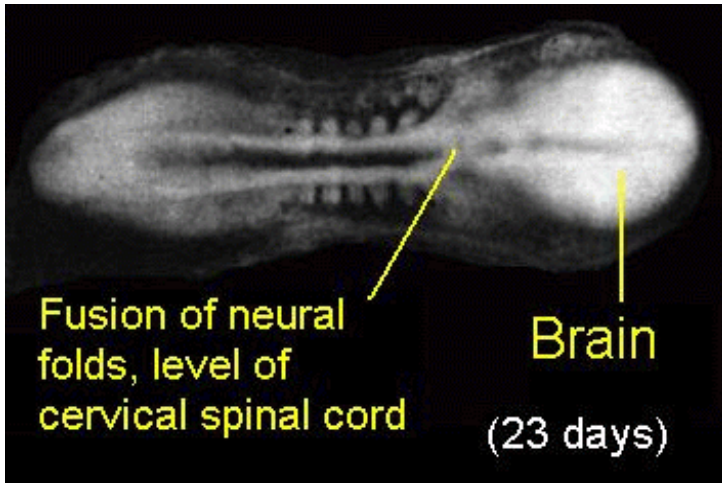

after fertilization, and by 18 days it is indented in the midline (**neural groove**) with enlargements on either side (**neural folds**). By 22 days the rostral ends of the neural folds are conspicuously enlarged; they will become the cerebral hemispheres. Fusion of the neural folds begins on Day 22 at a level that will eventually be that of the cervical segments of the spinal cord. Fusion proceeds rostrally and caudally, to form the **neural tube**. The initially open ends of the tube close on Day 24 (rostral neuropore) and Day 27 (caudal neuropore).

Failure of closure of a neuropore results in a severe developmental abnormality. In **anencephaly** the cerebral hemispheres and overlying skull and skin fail to develop. **Myeloschisis** is the equivalent condition for the spinal cord, due to failure of closure of the posterior neuropore. Related but less severe developmental abnormalities are the two types of spina bifida cystica: **meningocoele** and **meningomyelocoele**. In these conditions the caudal neuropore closes, but the mesodermal tissues (bone, dermis) dorsal to the spinal cord and nerve roots fail to develop, and there is a protrusion of dura, covered only by epidermis in the lumbar region. It may or may not contain nervous tissue.

MYELOSCHISIS

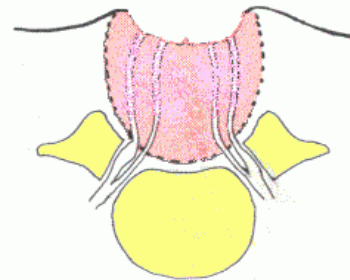

Missing: Roof plate
Vertebral arch
Skin

MENINGOCOELE MENINGOMYELOCOELE

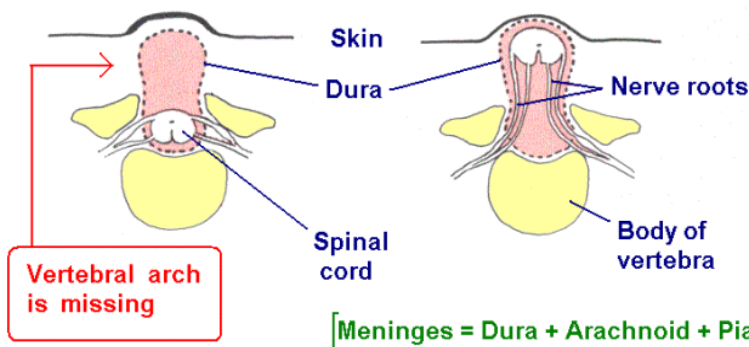

The caudal part of the spinal cord (below segment L2) is not derived from the neural tube. It originates from the caudal cell mass (= caudal eminence), a collection of pluripotential cells dorsal to the developing coccyx. These cells form a line of vesicles that fuse with one another and then with the caudal end of the neural tube.

The neural crest.

Drawings of transverse sections of embryos showing formation of the neural tube and crest.

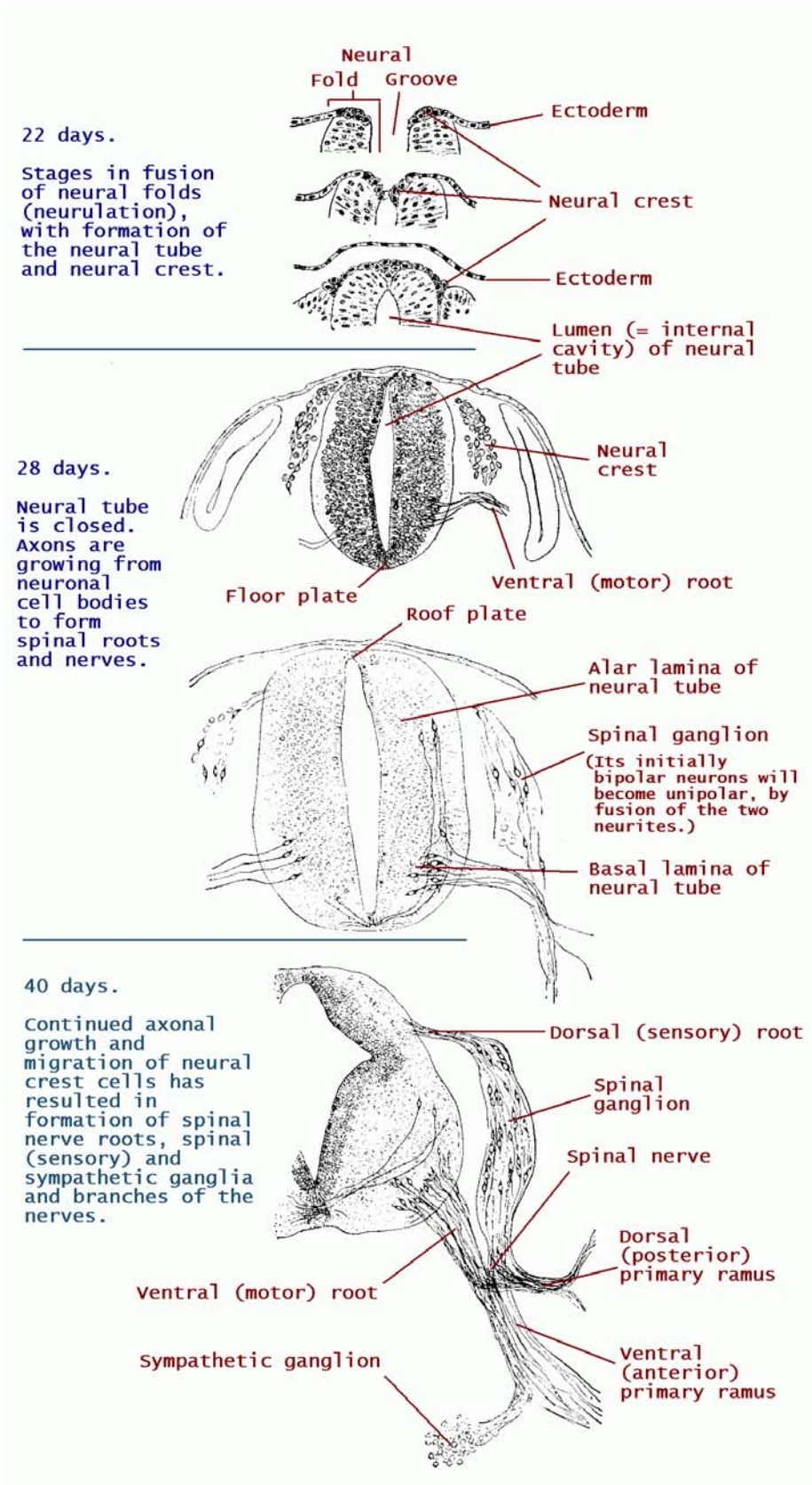

Alar and basal laminae.

On each side, many of the cells generated in the ventral part of the neural tube (the **basal lamina**, also called basal plate) are **motor neurons**. The axons of these cells elongate into the ventral roots of the spinal nerves and eventually supply skeletal muscles. The **primary sensory neurons** form in the neural crest. Their central projections are to the dorsal part of the neural tube, which is known as the **alar lamina**.

In the spinal cord, the basal lamina gives rise to the ventral (anterior) horn of grey matter, which is predominantly motor in function. The alar lamina becomes the dorsal (posterior) horn, which receives sensory input.

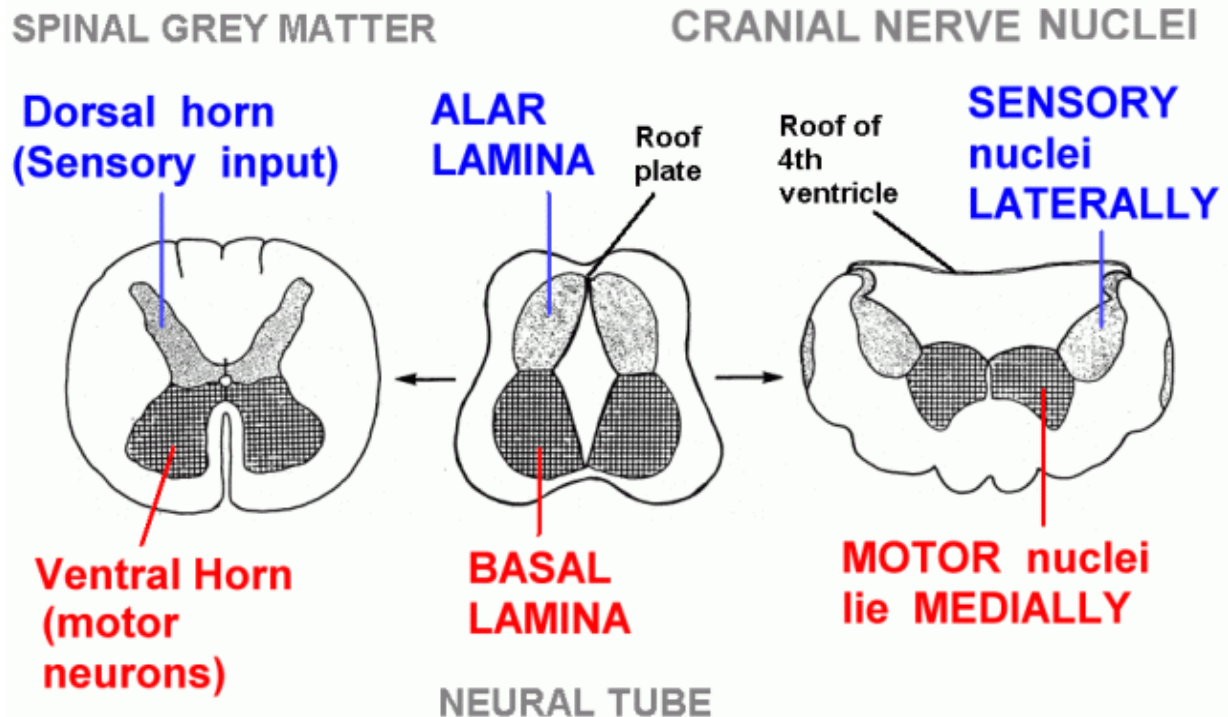

Moving rostrally from the spinal cord to the upper medulla and the pons, the roof plate becomes the wide, thin roof of the fourth ventricle, and the alar lamina is displaced from a dorsal to a lateral position. Consequently, in the brain stem the motor nuclei of cranial nerves are medial to sensory nuclei.

Meninges, ventricles and cerebrospinal fluid.

The meninges.

The outermost and strongest meninx is the **dura mater**, which adheres to the inside of the cranium. In the spinal canal, however the dura is not adherent to the vertebrae and their connecting ligaments. In places the dura splits and the resulting spaces, which carry venous blood that has left the brain, are called **dural venous sinuses**. Examples are the superior sagittal sinus, the straight sinus and the transverse sinuses. The dura is reflected into the cranial cavity to form rigid membranes. One is the **falx cerebri**, between the left and right cerebral hemispheres. Another is the **tentorium cerebelli** between the occipital lobes of the cerebrum and the upper surface of the cerebellum. The midbrain passes through a notch in the anterior edge of the tentorium.

The other two meninges are thinner than the dura. The pia mater is a microscopically thin layer of connective tissue that follows all the contours of the surface of the brain and spinal cord. The

arachnoid is a thicker layer; it is applied to the inside of the dura and separated from the pia by the **subarachnoid space**. The width of the subarachnoid space, which is filled with cerebrospinal fluid, is variable, being narrowest over the convexities of gyri and widest over sulci and other indentations of the brain. The subarachnoid space is traversed by delicate trabeculae of connective tissue. (The arachnoid is so-named because the trabeculae present an appearance that is reminiscent of a spider's web.)

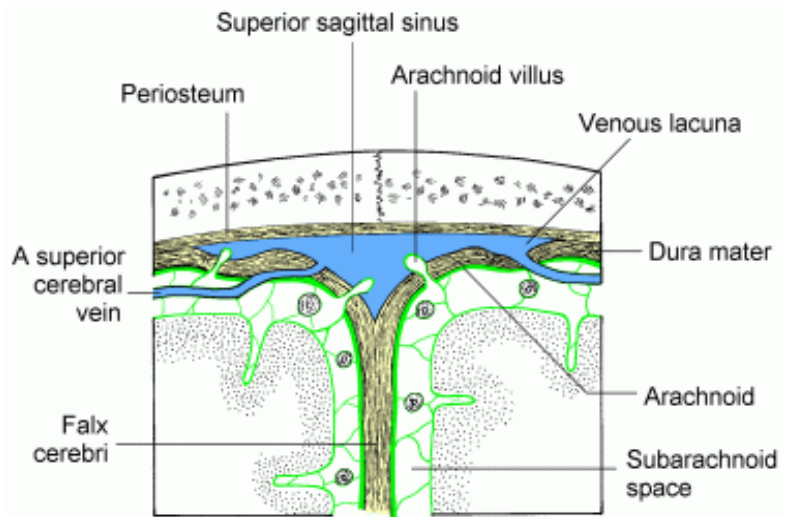

Veins draining the cerebral cortex travel in the subarachnoid space and then pierce the dura before emptying into the superior sagittal sinus. A head injury can result in tearing of one or more veins at these points. The escaping blood enters and widens the potential space between the arachnoid and the dura. The resulting accumulation, a subdural haematoma, presses on the cerebral hemisphere.

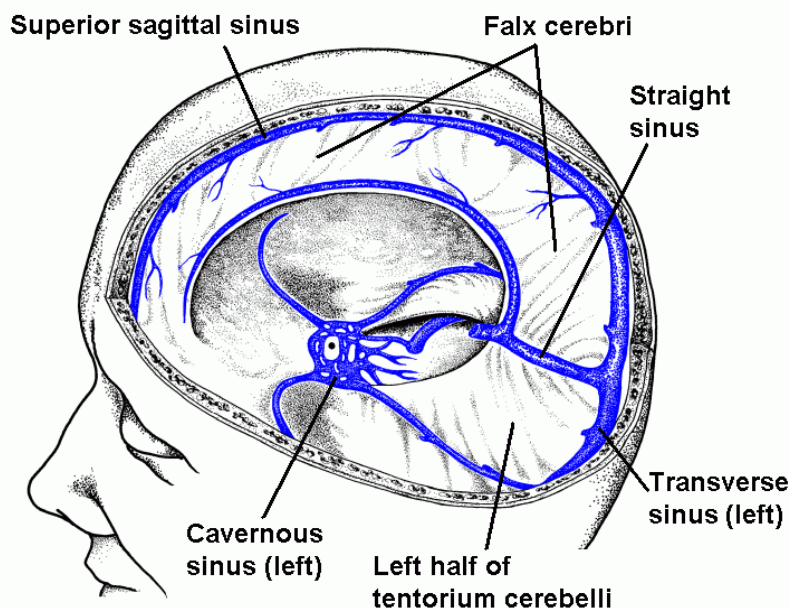

The wider regions of the subarachnoid space, known as cisterns, are important landmarks in neuroradiology. The largest intracranial cistern is below the cerebellum and above the medulla; it is called the **cerebellomedullar cistern** or **cisterna magna**. The **cisterna ambiens** surrounds the midbrain, and the **lumbar cistern** is below the caudal end of the spinal cord.

The **arachnoid granulations** are small protrusions of the arachnoid membrane through the dura into the sinuses. They are most numerous along the sides of the superior sagittal sinus. Arachnoid granulations

are the conduits through which cerebrospinal fluid passes from the subarachnoid space into the venous blood.

Cerebrospinal fluid (CSF).

The brain and spinal cord are suspended weightlessly in the CSF, which is a colourless liquid similar in composition to blood plasma, but without the proteins. The CSF protects the central nervous system by providing a liquid cushion between the fragile nervous tissue and the bones of the skull and vertebral column. CSF is secreted by the **choroid plexuses** of the four ventricles of

the brain. The largest choroid plexuses are those of the lateral ventricles. Choroid plexus is a richly vascular tissue in which permeable capillary blood vessels are enclosed in a secretory epithelium.

CSF leaves the ventricular system by way of three holes in the roof of the fourth ventricle. The largest is the **median aperture** (foramen of Magendie), through which the fluid passes into the cisterna magna. The smaller **lateral apertures** are in the cerebellomedullary angle, between the flocculus and the rootlets of cranial nerves IX and X. In the subarachnoid space CSF flows upward and forward around the brain stem and cerebellum, up through the **cisterna ambiens** (around the midbrain, flanked by the tentorial notch), and then around the cerebral hemispheres to the main site of absorption, the arachnoid granulations beside the superior sagittal sinus.

When a sample of cerebrospinal fluid is required for diagnostic purposes, the needle is introduced into the lumbar cistern, between the dorsal spines of vertebrae L4 and L5 or L3 and L4, below the caudal end of the spinal cord. A lumbar puncture should not be performed if raised intracranial pressure is suspected; withdrawal of fluid from the lumbar cistern could precipitate **medullary coning**, a fatal condition in which the medulla, and the tonsils of the cerebellum are forced through the foramen magnum.

Raised intracranial pressure causes headache, vomiting and **papilloedema**. The last-named sign is swelling and venous congestion in the optic disc, easily seen with an ophthalmoscope. The swelling results from transmission of the raised pressure through the subarachnoid space of the optic nerve (which is part of the central nervous system).

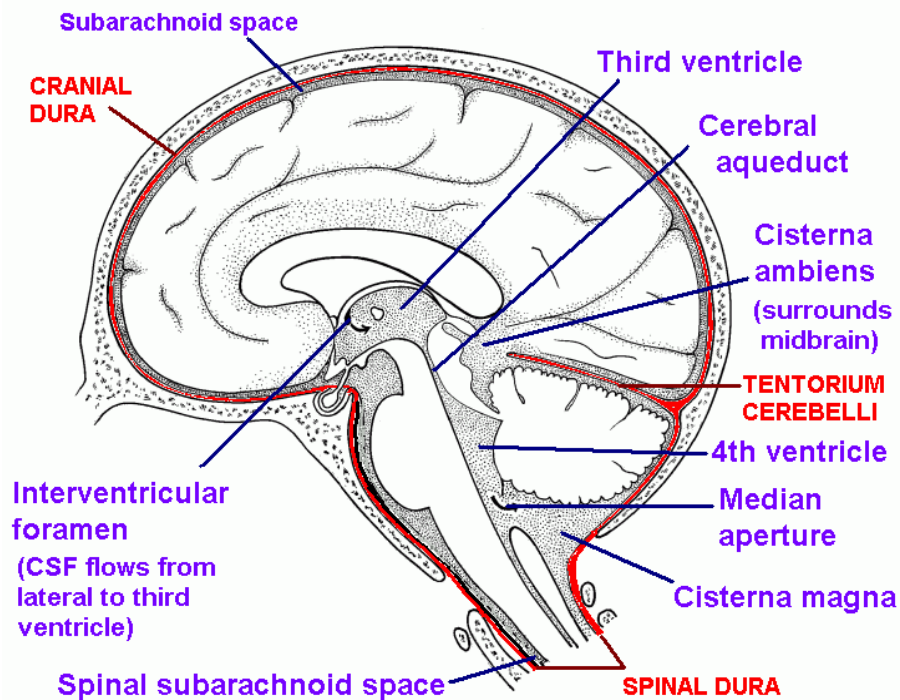

Hydroc

ephalus develops when CSF is being secreted but not absorbed. In young children the head enlarges; in adults there can be loss of brain tissue. **Internal hydrocephalus** is confined to the ventricular system (*e.g.* with narrowing or absence of the cerebral aqueduct both lateral ventricles become dilated).

Communicating hydrocephalus occurs when the flow of CSF through the subarachnoid space or arachnoid granulations is blocked (*e.g.* by pus and scarring in bacterial meningitis, or by blood following haemorrhage into the subarachnoid space). The abnormally large volume of CSF around a shrunken brain (*e.g.* in Alzheimer's disease) is sometimes called **hydrocephalus ex vacuo**.

Peripheral nervous system

The nervous system develops from embryonic segments, but in the adult state this is obvious only in the connections of nerve roots with the spinal cord.

Segmental organization

The formation of a spinal nerve is illustrated in Fig 1. This diagram also shows structural elements that will be referred to later. Spinal nerves have numbers derived from the vertebrae. The highest spinal nerve penetrates the atlanto-occipital membrane, *above* the arch of the atlas, which is the first cervical vertebra or C1. The second cervical nerve passes between the atlas (vertebra C1) and the axis (C2). There are 7 cervical vertebrae. The lowest cervical nerve is therefore C8. Cervical nerves 1 to 7 go through foramina *above* the numbered vertebrae. The roots of nerve C8 pass below the arch of vertebra C7 and above that of T1. All the thoracic (T1 - T12), lumbar (L1 - L5) and sacral (S1 - S5) nerves go through foramina *below* the equivalently numbered vertebrae. To complete the story, a single coccygeal nerve overlaps with S5 in supplying the perianal skin.

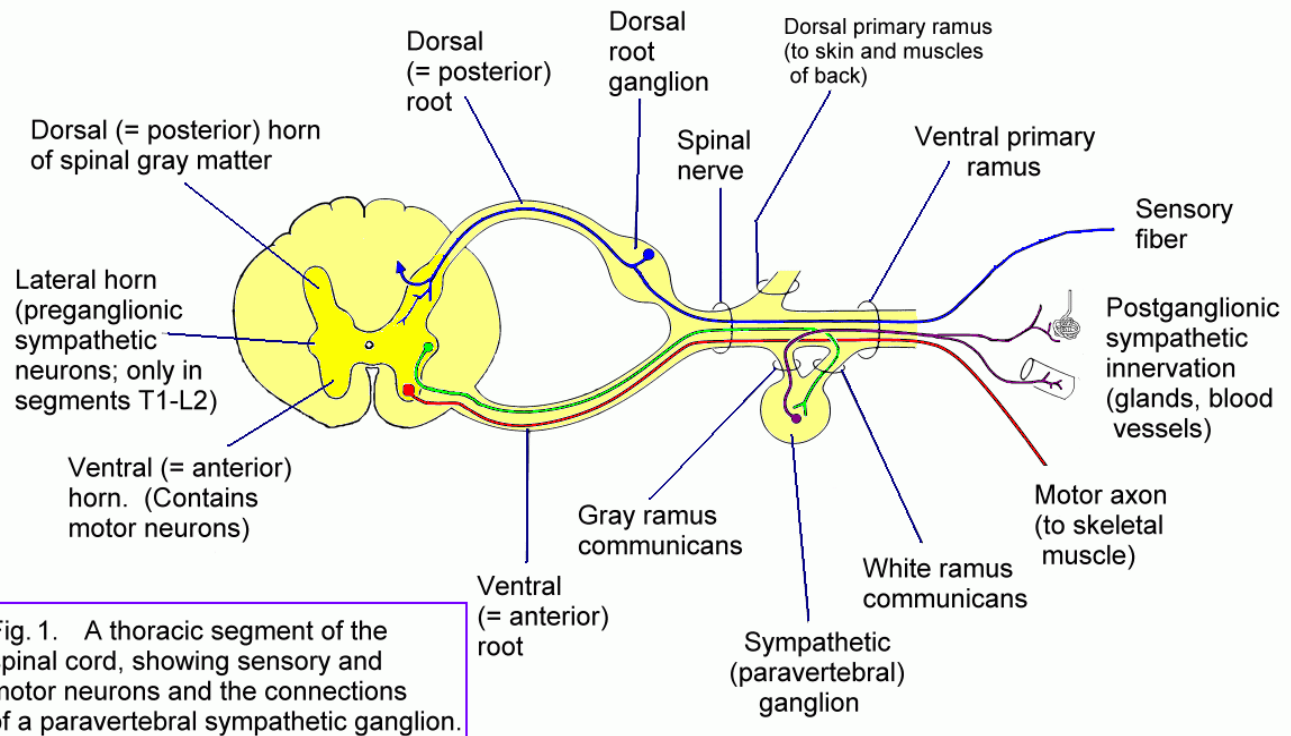

The most obvious consequence of the segmental organization of the spinal nerves is seen in the **Dermatomes**, which are bands of skin that run horizontally on the trunk and lengthwise on the limbs (Fig. 2). Each dermatome is centered on the distribution of axons from a single dorsal root ganglion, but each ganglion also supplies skin in the dermatomes above and below its own level. Consequently, it is necessary to transect three adjacent dorsal roots or spinal nerves in order to completely denervate the skin of one dermatome. Transection of a single spinal nerve, or destruction of its ganglion, diminishes but does not abolish sensation in the affected segment of skin. The cutaneous lesions of herpes zoster, a common virus that infects certain pain-responsive neurons in individual sensory ganglia, often neatly map the distributions of dermatomes and also illustrate the extension of innervation into the adjacent segments of skin. The nerve supply to the skin of the limbs is delivered by **cutaneous nerves** that are formed in **limb plexuses** (brachial and lumbosacral) by complex interchanging and mixing of fibers from different spinal roots. The areas supplied by cutaneous nerves bear little resemblance to the dermatomes. They are sharply demarcated, with little or no territorial overlapping (Fig. 2). The widely overlapping dermatomes

cut across adjacent areas of skin supplied by cutaneous nerves. A cutaneous nerve lesion, such as an injury or a mononeuropathy, results in a well defined area of defective sensation, and anatomical knowledge can be used to identify the affected nerve.

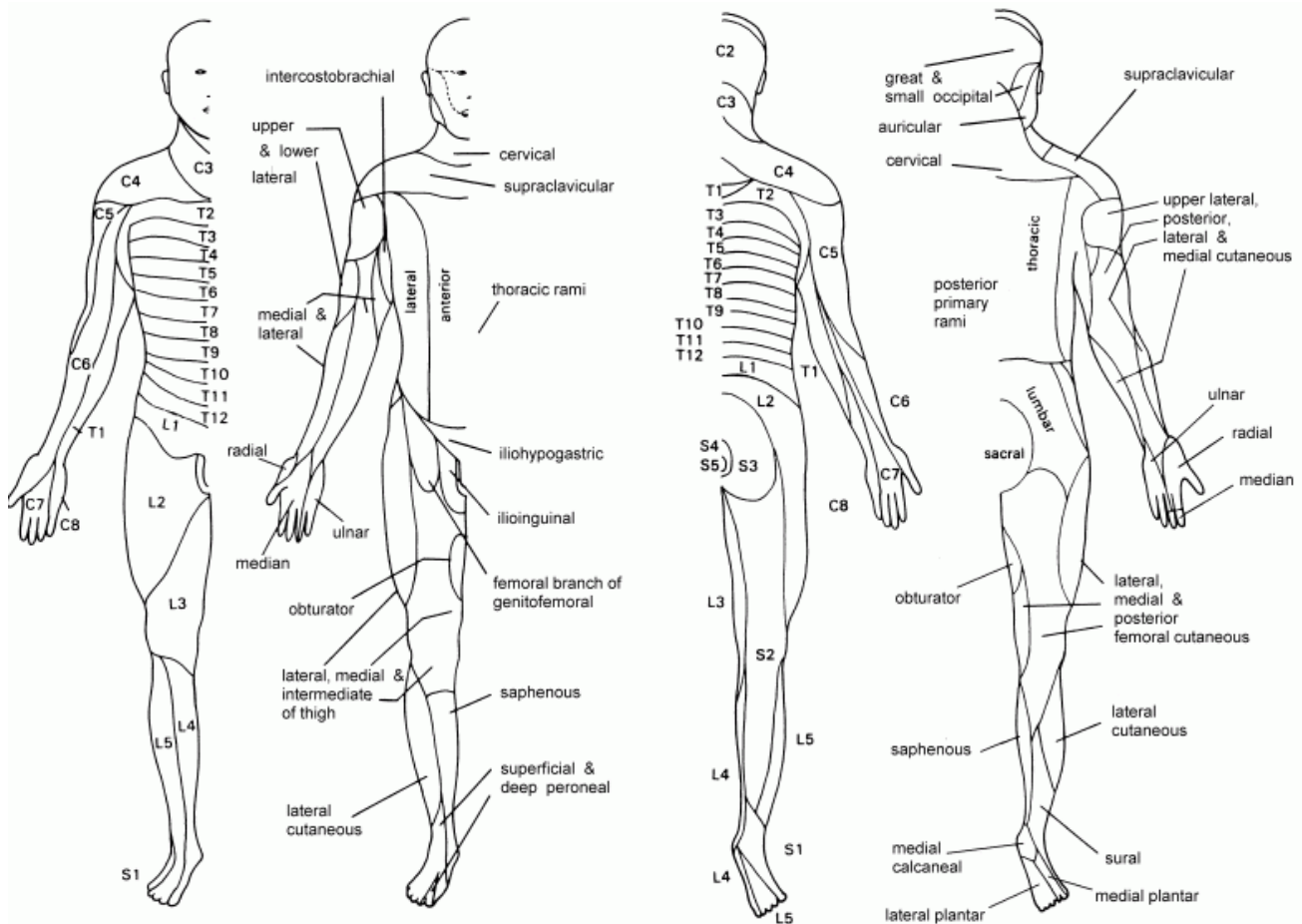

Fig. 2. Segmental innervation of the skin, and areas supplied by the larger cutaneous nerves. A chart such as this can be used to diagnose a lesion that affects an individual nerve or root. [With permission, from Romero-Sierra C 1986. *Neuroanatomy, a conceptual approach*. New York: Churchill Livingstone.]

Most of the skin of the head is supplied by the three divisions of cranial nerve V. The areas are sharply demarcated, and therefore do not correspond to dermatomes. Cranial nerves VII, IX and X supply small, overlapping areas of skin of the external ear, and the dermatome of the second cervical nerve includes parts of the head, ear, face and neck. (The first cervical nerve lacks a dorsal root in most people.)

Muscles receive motor and sensory innervation. Most of the muscles of the limbs are supplied nerves formed in the limb plexuses from two or more roots. **Table 2** shows the segmental innervation of a few clinically important muscles. A **stretch reflex** (tendon jerk) requires the integrity of both the motor and the proprioceptive sensory innervation of the muscle.

Relation of spinal cord and nerve roots to the vertebral column

The vertebral column is longer than the spinal cord, which ends at the level of the upper border of vertebra L3 in the newborn and at the upper border of vertebra L2 in the adult. The lower spinal nerves must therefore course caudally before passing through their corresponding intervertebral foramina. Immediately below the caudal end of the spinal cord, the neural canal contains the roots of nerves L2-L5, S1-S5 and the coccygeal nerve.

TABLE 2. Useful landmarks of skin and muscle innervation

Skin	Muscles (and stretch reflexes)
C2 occipital region of head	C5-C6 flexion of elbow (biceps jerk)
C5 tip of shoulder	C7-C8 extension of elbow (triceps jerk)
C6 thumb	C8-T1 small muscles of hand
C8 little finger	L2-L3 quadriceps (knee jerk)
T4-T5 nipple	S1-S2 calf muscles (ankle jerk)
T10 umbilicus	
L3 front of knee	
L5 big toe	
S1 little toe, heel	
S3 genitalia and	
and anal area	
below	

A lesion arising from the axial skeleton, such as a herniated intervertebral disk or tumor tissue from a vertebral body or pedicle, can press on the spinal cord or spinal nerves. The consequences depend on the level of the involved disk or vertebra. In the cervical and upper thoracic spine there is little discrepancy between the spinal segments and the vertebrae. There is little free space in this part of the neural canal, so a lesion is likely to impinge on the cord as well as on a spinal nerve. The body of vertebra T10 is level with spinal cord segment T11. Below this level, the discrepancy between vertebral and spinal levels increases rapidly, because the lower lumbar and the sacral segments of the spinal cord are much shorter than the cervical and thoracic segments. All the spinal cord segments below T11 are in the range of just three vertebrae, T12, L1 and L2.

The foramina are above the levels of the intervertebral disks. Consequently, a herniated disk below C7 cannot compress its own segmental nerve; it presses on the nerve one or two segments lower. *For example*, an L4-5 disk herniation commonly compresses spinal nerve L5 or S1, causing pain and other sensory abnormalities in the appropriate dermatomes (see Fig. 2).

Cranial nerves

Although the brain stem from segments (known as neuromeres), their peripheral distributions and central connections are most easily understood in terms of the functions of each nerve. These are set out in Table 3. Note that the second cranial "nerve," despite its traditional name, is not a nerve but an outgrowth of the brain, as is the retina.

TABLE 3. Functions of the cranial nerves.

This table includes functional components that can be tested by clinical examination or that cause symptoms if affected by disease. Minor components and physiological afferents from internal organs¹ are omitted.

Cranial nerve	Functional components			
	Motor (= supplying skeletal muscle)	Preganglionic ² parasympathetic membranes)	General sensory (skin, mucous)	Special senses
I Olfactory				Smell.
II Optic				Vision.
III Oculomotor	Eye movements other than those mediated by IV & VI. Elevation of upper eyelid.	Constriction of pupil (ciliary ganglion).		
IV Trochlear	Certain downward eye movements.			
V Trigeminal	Muscles that open and close the mouth; Tensor tympani muscle of middle ear.		Skin of face; mouth, teeth, nose, sinuses, dura mater of anterior & middle fossa.	
VI Abducens	Abduction of eye			
VII Facial	Muscles of face; stapedius muscle of middle ear. sublingual & submandibular salivary glands (submandibular ganglion).	Lacrimal and nasal glands (pterygo-palatine ganglion);		Taste: palate anterior 2/3 of tongue.
VIII Vestibulocochlear:				
	Vestibular			Equilibration.
	Cochlear			Hearing.
IX Glossopharyngeal		Parotid gland (Otic ganglion)	Pharynx, middle ear, posterior third of tongue	Taste: posterior third of tongue.

X Vagus	Muscles of larynx and pharynx	Slows heart; (cardiac ganglia) Increases gastric acid secretion.	Larynx, trachea, esophagus, dura of posterior fossa.	Taste: epiglottis.
IX Accessory³ (Spinal component)	Trapezius and sternocleidomastoid muscles			
XII Hypoglossal	Muscles that move the tongue.			

¹ Afferent fibers in IX and X are of great importance for regulation of cardiovascular and respiratory function, but they do not give rise to conscious sensations, and the physiological functions are not usually disturbed by unilateral lesions that affect the nerves or their central connections.

² The names of the parasympathetic ganglia are indicated in parentheses after the functions.

³ The small cranial root of XI carries motor axons destined mostly for the larynx. These cross over into X by way of a communicating branch, as the two nerves pass through the jugular foramen in the base of the skull. The fibers of the spinal root have their cell bodies in segments C1-C5 of the spinal cord.

Autonomic nervous system

Skeletal muscles are supplied by motor neurons whose cell bodies are in the spinal cord (anterior horn) or brain stem (motor nuclei of cranial nerves). In contrast, glands, cardiac muscle, and the smooth muscle of blood vessels and internal organs are supplied by neurons in ganglia of the autonomic system. These ganglia receive afferent **preganglionic fibers**, which are the thinly myelinated axons of neurons in the spinal cord or brain stem. The neurons in the ganglia have unmyelinated axons, the **postganglionic fibers** that innervate smooth and cardiac muscle and secretory cells. There are three divisions of the autonomic system: sympathetic, parasympathetic and enteric.

The ganglia of the **sympathetic** system are the chains of **paravertebral ganglia** that lie on the lateral aspects of the bodies of the vertebrae, and also the **Preaortic** or **collateral** ganglia associated with the branches of the aorta that supply abdominal organs. There is a sympathetic chain ganglion for every spinal nerve. Postganglionic fibers enter the nerve by way of a **gray ramus communicans** (See Fig. 1) and are distributed to blood vessels, sweat glands and the little muscles that move hairs. Blood vessels of the skin constrict in response to their sympathetic supply, whereas those in muscles dilate. Some of the ganglia for the nerves C1 to T1 are fused; consequently there are only three cervical sympathetic ganglia. In most people there is a **stellate ganglion**, formed from inferior cervical (C7-C8) and first thoracic ganglia. The **middle cervical ganglion** is connected with nerves C5 and C6. Postganglionic fibers from the large **superior cervical ganglion** (C1-C4) accompany the carotid artery and its branches. Some enter the eye, where they supply the **dilator pupillae** muscle of the iris. Others supply smooth muscle within the **upper eyelid**. All three cervical ganglia send postganglionic fibers into **cardiac nerves**, which run alongside the common carotid artery and aorta and supply the muscle of the heart. Increased activity of the sympathetic system increases the rate and force of contraction of the heart.

Preganglionic sympathetic neurons are present only in spinal cord segments T1 to L2, where they occupy the lateral horn of the gray matter. Their myelinated axons constitute the **white rami communicantes** (see Fig. 1), which are associated only with nerves and ganglia T1-L2.

Preganglionic fibers destined for sympathetic ganglia above and below these levels pass rostrally and caudally in the **sympathetic trunk**, which interconnects all the ganglia of the sympathetic chain. Some preganglionic fibers pass through thoracic sympathetic ganglia and emerge as the roots of the greater (T5-T9), lesser (T10-T11) and lowest (T12) **splanchnic nerves**. These nerves pass behind the diaphragm and end in the preaortic ganglia. Some go to the adrenal medulla (which is a sympathetic ganglion modified to secrete its transmitter into the blood). The efferent axons from the preaortic ganglia accompany blood vessels to abdominal organs, where most end by synapsing with neurons of the enteric nervous system (see below).

Parasympathetic ganglia are found in the head, connected with certain cranial nerves, and associated with the walls of thoracic and pelvic viscera. Preganglionic fibers leave the brain stem in cranial nerves III, VII, IX and XI and terminate in cranial parasympathetic ganglia. The neurons in these ganglia supply the structures whose functions are stated in Table 3. The cardiac ganglia receive their preganglionic afferents from the vagus nerve; their neurons supply cardiac muscle cells, principally in the atria. The **pelvic splanchnic nerves**, branches of S2, S3 and S4, carry preganglionic fibers to the parasympathetic ganglia that supply the detrusor muscle of the urinary bladder and the blood vessels of erectile tissue in the genitalia.

The **enteric nervous system** consists of thousands of tiny, interconnected ganglia in the walls of the alimentary canal, from esophagus to anus, and of some of its associated structures such as the biliary system and pancreas. These ganglia, which supply the smooth muscle and secretory tissues of the gut, contain several types of neurons, with a wide variety of neurotransmitters. The enteric nervous system can do much of its work independently, but it is modulated by preganglionic fibers from the vagus nerve (to the stomach, small intestine and first half of the colon) and from the pelvic splanchnic nerves (distal colon and rectum). Parasympathetic activity stimulates propulsion of the contents of the gut. Of the vagal fibers that enter the abdomen, a majority end in enteric ganglia of the stomach, and the integrity of this preganglionic supply is essential for acid secretion and for opening of the pyloric sphincter.

Most of the postganglionic sympathetic fibers from the preaortic ganglia synapse with neurons in enteric ganglia, but some contact blood vessels and a few supply intestinal smooth muscle. Activity of the sympathetic system causes constriction of visceral blood vessels and retards propulsion of the contents of the alimentary canal.

Regional anatomy of the central nervous system

The cerebral cortex, which covers much of the surface of the brain, is often considered to be the seat of consciousness and thinking. It receives sensory pathways, interprets the sensations, formulates commands and sends orders through motor pathways to the muscles. Although this simplistic view of neural organization is not entirely correct it has served neurologists well for more than a century, and it is still a useful starting point for anyone starting to study functional neuroanatomy. From caudal to rostral, the major divisions of the central nervous system are the **spinal cord**, the hind-brain (**medulla, pons and cerebellum**), the **midbrain** and the **forebrain** or cerebrum, which consists of two **cerebral hemispheres**. (see Fig. 3). The **brain stem** comprises the medulla, pons and midbrain. The cerebellum is joined to each part of the brain stem by paired peduncles of white matter. There are therefore 6 **cerebellar peduncles**. The ventral part of the midbrain, on each side, is called a **cerebral peduncle**, because its ventral part contains great numbers of fibers descending from the cerebral hemisphere.

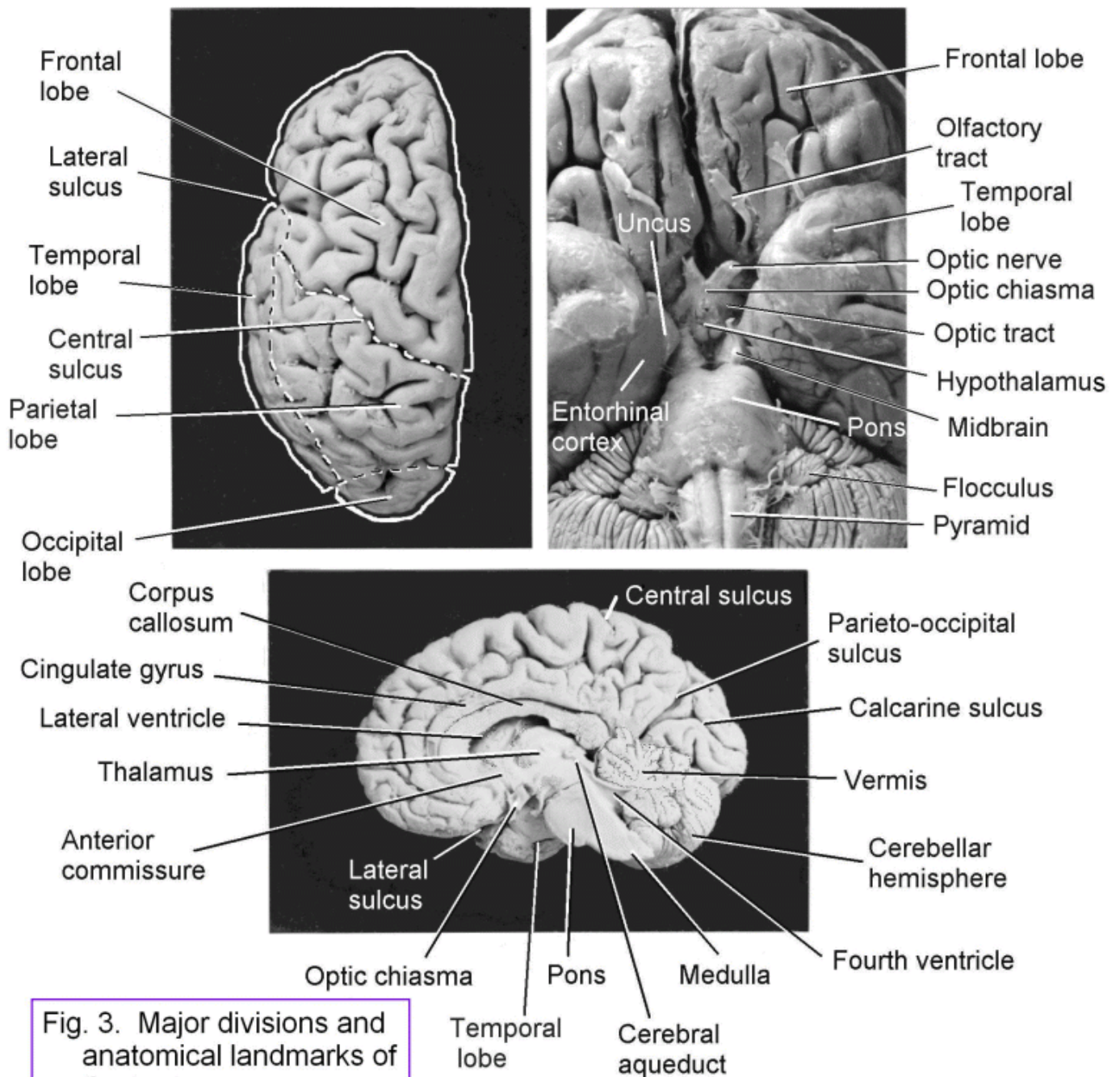

Fig. 3. Major divisions and anatomical landmarks of the brain.

Fig. 3 also shows some other external landmarks, which will be mentioned later in the text.

Spinal cord

The neural components of the spinal cord are most easily understood in a transverse section through segment T1, which is connected with the nerves of the upper limb. All the ascending and descending tract are present at this level, and so are certain cell columns that occur only in the thoracic and upper lumbar segments (Fig. 4). The small **central canal** of the spinal cord, which contains cerebrospinal fluid, is a remnant of the lumen of the embryonic neural tube.

The effects of a destructive lesion in the spinal cord can be predicted from knowledge of the segmental level and the functions of the tracts shown in Fig. 4. For example, A penetrating injury that transects the left half of the spinal cord in segment T4 will cause paralysis of abdominal and lower limb muscles on the left, loss of discriminative touch and proprioceptive

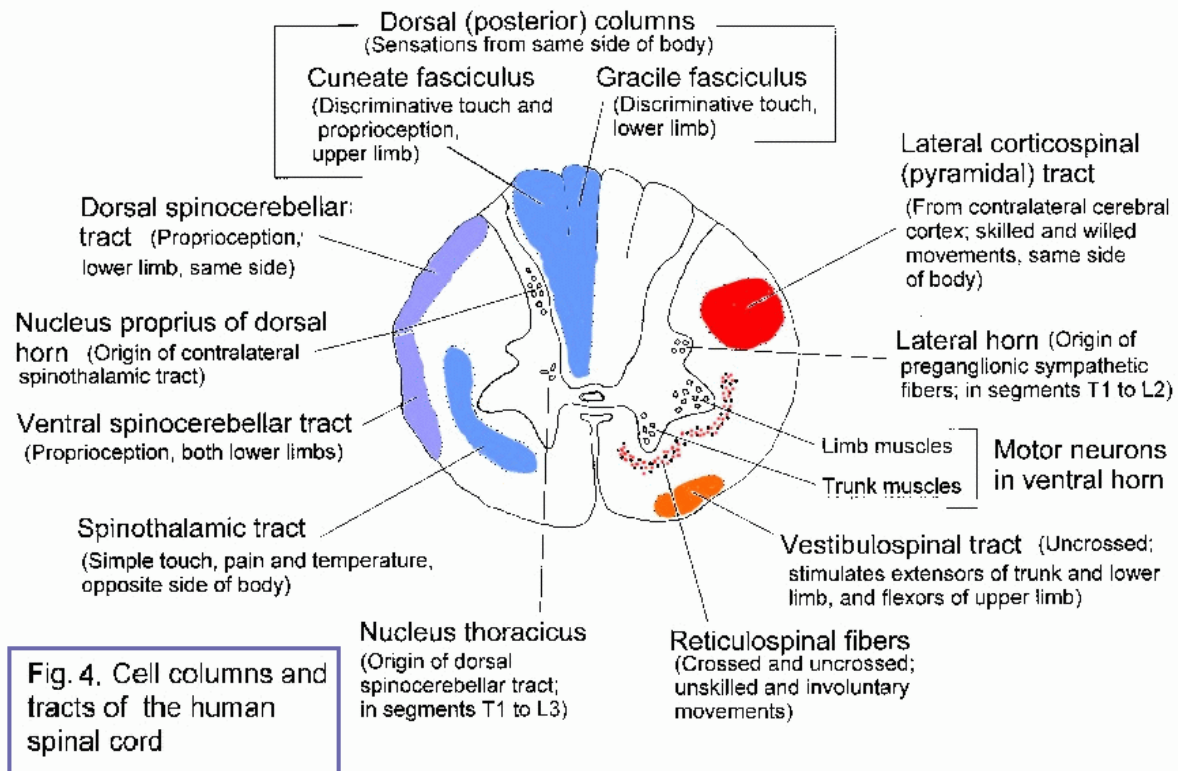

sensation everywhere below the level of the nipple on the left side, and loss of pain and temperature sensibility below the level of the nipple on the right side.

Brain stem

The central canal of the spinal cord continues through the caudal half of the medulla and then widens to form the diamond-shaped **fourth ventricle**, which is the cavity of the upper medulla and of the pons. The roof of the fourth ventricle is very thin; cranial nerve nuclei form much of the floor of this ventricle, and the inferior and superior cerebellar peduncles form its walls. Cerebrospinal fluid flows from the ventricular system of the brain into the subarachnoid space through apertures in the thin roof of the fourth ventricle. At the rostral border of the pons the fourth ventricle becomes the **cerebral aqueduct**, which is the narrow, tubular cavity of the midbrain. Dorsal to the aqueduct is the **tectum** ("roof"), a substantial slab of gray matter organized into four "little hills:" the paired **inferior** and **superior colliculi**, which form parts of the pathways for hearing and eye movements, respectively.

Some of the fiber tracts of the spinal cord extend also throughout the brain stem; others begin or end there. The brain stem also contains the nuclei of cranial nerves III-XII. The motor nuclei correspond to cells of the ventral horn of the spinal gray matter, and some sensory nuclei correspond to the dorsal horn. Other cranial nerve nuclei have no obvious equivalence to cell columns of the spinal cord. Other major groups of neurons in the brain stem include nuclei connected with the cerebellum and the several cell groups that comprise the reticular formation. Fig. 5 shows the approximate levels of cranial nerve nuclei and the positions of some tracts. The interested reader will need to consult a textbook of neuroanatomy for more detailed information.

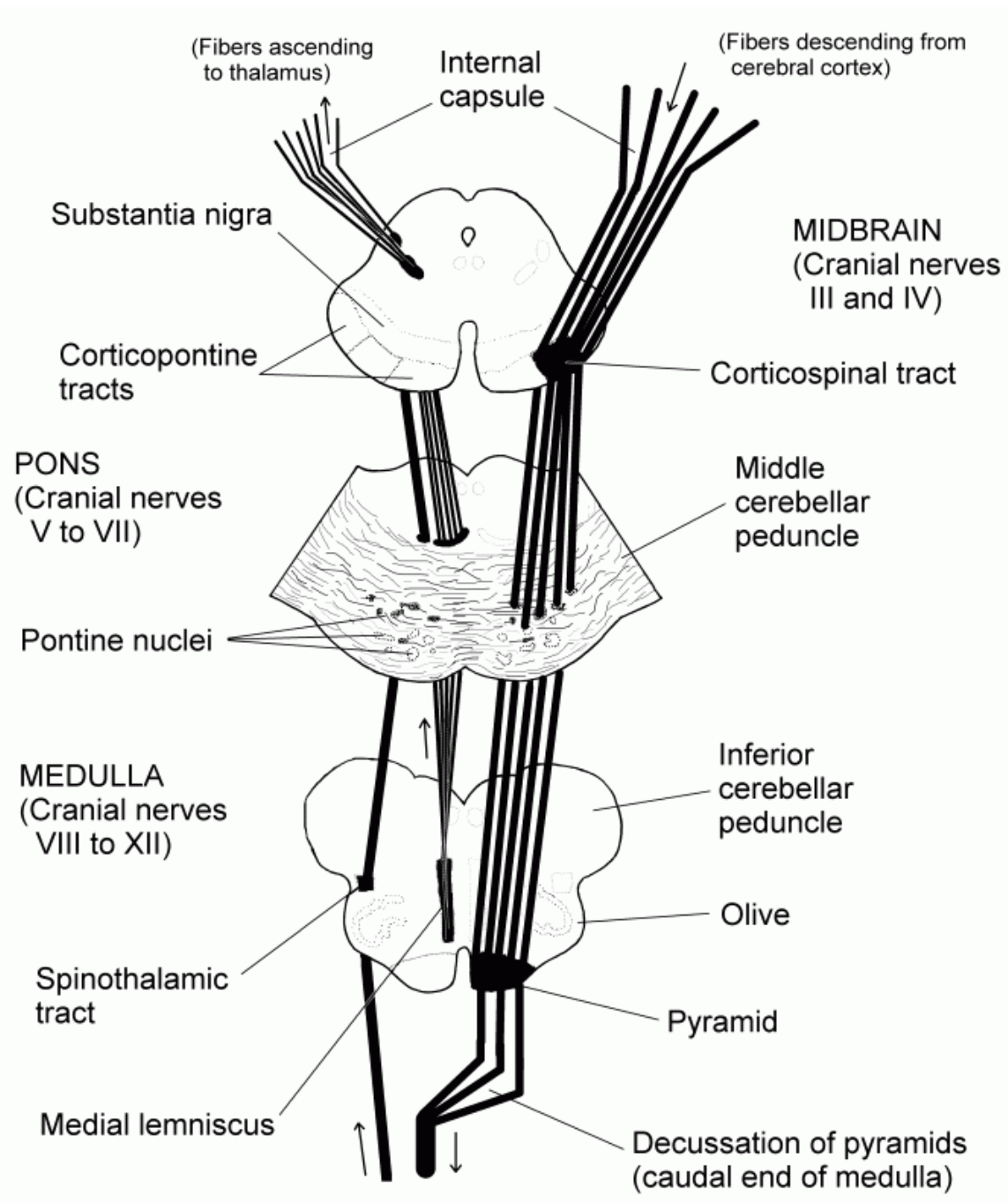

Fig. 5. Diagram of the brain stem showing principal ascending and descending tracts and mentioning a few nuclei and cranial nerves. The reticular formation (not labeled) occupies much of the dorsal part of the brain stem, and is traversed by some of the tracts.

The most ventral parts of the midbrain, pons and medulla contain large numbers of fibers from the cerebral cortex that have predominantly motor functions: the **corticopontine** and **corticospinal tracts**. There are also **corticobulbar** fibers, which end in or near the motor nuclei of cranial nerves in the "bulb" (medulla and pons).

Two of the cranial nerve nuclei are greatly elongated. Each is a column of neurons alongside a tract, which is composed of afferent fibers from a sensory ganglion. The **spinal trigeminal nucleus** extends downward from a mid-pontine level until it blends with the dorsal horn of the spinal gray matter. It receives the general sensory fibers from the head and the upper end of the gastrointestinal and respiratory tracts; most of these enter the brain stem through the trigeminal and glossopharyngeal nerves. The caudal end of the spinal trigeminal nucleus receives afferents concerned with pain and thermal sensations. The rostral end is concerned with touch, as is the pontine trigeminal nucleus. The **solitary nucleus**, which extends the length of the medulla, receives afferent fibers from cranial nerves VII, IX and XI. The afferents to the rostral end of the nucleus are sensory neurons that innervate taste buds. The caudal end of the solitary nucleus receives signals from sensory receptors in the heart, carotid sinus, carotid body, lungs and other internal organs; it is concerned with physiological regulation of the circulatory and respiratory systems.

A large destructive lesion in the brain stem is fatal. A small, circumscribed lesion interferes with the functions of the transected tracts and of nuclei and fibers of cranial nerves. Cerebellar symptoms are present, ipsilaterally, with lesions that erode the superior or inferior cerebellar peduncle.

Cerebellum

The cerebellum consists of a midline portion, the **vermis**, flanked by the two **cerebellar hemispheres**. It has a convoluted cortex, white matter, and central nuclei. All cerebellar afferent fibers branch to end in the nuclei and cortex. The cortex projects to the underlying nuclei, which are the source of the efferent fibers of the cerebellum. As stated earlier, three peduncles on each side connect the cerebellum with the brain stem.

The best known action of the cerebellum is to ensure the correct extent and timing of movements, though additional functions have also been postulated. Cerebellar afferents come from many parts of the central nervous system, the best understood being the spinal cord, the vestibular nuclei and certain other nuclei in the brain stem, notably the inferior olivary and pontine nuclei. The cerebellum is conveniently divided into three anatomically distinct functional parts, on the basis of its afferent connections.

The **vestibulocerebellum** is the smallest division, with a small midline component, the **nodule**, and connected parts of each hemisphere, the **flocculi**. Afferent fibers are from the vestibular ganglion and the vestibular nuclei, which are in the rostral part of the medulla. The cortex of the vestibulocerebellum projects to the **fastigial nuclei**, which are embedded in the white matter of the vermis, above the roof of the fourth ventricle. The neurons in the fastigial nucleus have axons that enter the medulla and end mainly in the vestibular nuclei. These connections make the functions of the vestibulocerebellum inseparable from those of the vestibular system. Similar clinical manifestations (vertigo, nystagmus, nausea) follow damage to the vestibular apparatus, nerve, nuclei or vestibulocerebellum, or to the inferior cerebellar peduncle, which carries the connecting fibers.

The **spinocerebellum** consists of the vermis and adjacent cortex of much of the rostral part ("anterior lobe") of the cerebellum. It receives the **spinocerebellar tracts** (Fig 4) and the related **cuneocerebellar tract**, which relays proprioceptive signals from the upper limb. The cortex projects to the underlying **interposed nuclei**, and these in their turn send axons through the superior cerebellar peduncle to the contralateral red nucleus (in the midbrain) and thalamus. The spinocerebellum is driven by proprioceptive input, so if there is a lesion in the midline of the

upper part of the cerebellum the motor systems fail to respond quickly to signals coming from muscles, tendons and joints. This results in poorly controlled movement (cerebellar ataxia), especially of the muscles of the trunk and lower limbs.

The **pontocerebellum** is the largest division, comprising most of the hemispheres and the posterior part of the vermis. The middle cerebellar peduncle, the largest, consists entirely of fibers from the contralateral **pontine nuclei** (Fig. 5), and the decussating pontocerebellar fibers account for the appearance and size of the ventral part of the pons. The pontine nuclei receive their afferents from extensive areas of the cerebral cortex. The deep nucleus of the pontocerebellum is the **dentate nucleus**, in the center of the hemisphere, and this send axons through the superior cerebellar peduncle to the thalamus, along with the efferents from the interposed nuclei. The ventral lateral thalamic nucleus, which receives the fibers from the cerebellum, projects to the primary motor area of the cerebral cortex. Thus, the pontocerebellum is influenced by activity in most of the contralateral cerebral cortex, and modulates movements by acting upon the primary motor area. Pontocerebellar disorders can be due to lesions in the dentate nucleus or in the white matter of the cerebellar hemisphere or superior cerebellar peduncle. The clinical signs, which are ipsilateral, affect the accuracy of performance of movements and include the classical manifestations of cerebellar disorder, such as dysdiadochokinesis, past-pointing and intention tremor.

It remains to be stated that all areas of the cerebellum receive input from the **inferior olivary nuclei** of the medulla. Afferents to the inferior olivary complex of nuclei are from the motor areas of the cerebral cortex and from the spinal cord. Physiological studies in animals indicate that the cerebellum uses its olivary afferents when learning patterns of instructions for carrying out movements. The more specific connections, described in the preceding paragraphs, are put to use in the execution of the learned patterns.

Cerebral hemisphere

The structural organization of the cerebrum and its connection with the brain stem are best appreciated in a frontal (coronal) section of the brain that passes through the ventral part of the midbrain (Fig. 6).

The rostral end of the midbrain merges with the **diencephalon** ("between brain"), which has four subdivisions on each side, separated by the **third ventricle**, which is a slit-like cavity in the midline.

The **subthalamus**, which is closest to the midbrain, contains the **subthalamic nucleus**, which is involved in motor circuitry, and ascending tracts that are about to terminate in the thalamus: the medial lemniscus, spinothalamic tract and fibers from the cerebellum.

The **hypothalamus** is medial and rostral to the subthalamus, and has landmarks on the inferior (ventral) surface of the brain. This region controls important autonomic and endocrine functions. Neural and vascular links from the hypothalamus control the pituitary gland.

The **Thalamus** is the largest part of the diencephalon. It forms much of the wall of the third ventricle and floor of the lateral ventricle. It's many constituent nuclei communicate with the cerebral cortex. Most thalamic nuclei also receive input from subcortical sources and some are stages in pathways for sensory, motor and cognitive activities. At the anterior (rostral) end of each thalamus, the third ventricle becomes continuous with the lateral ventricle, through the **interventricular foramen** of Monro.

The **Epithalamus** is a poorly understood region of the brain associated with the junction of the cerebral aqueduct and third ventricle. It includes the **pineal gland**, a much studied but still mysterious probable endocrine organ, which is dorsal to the superior colliculi.

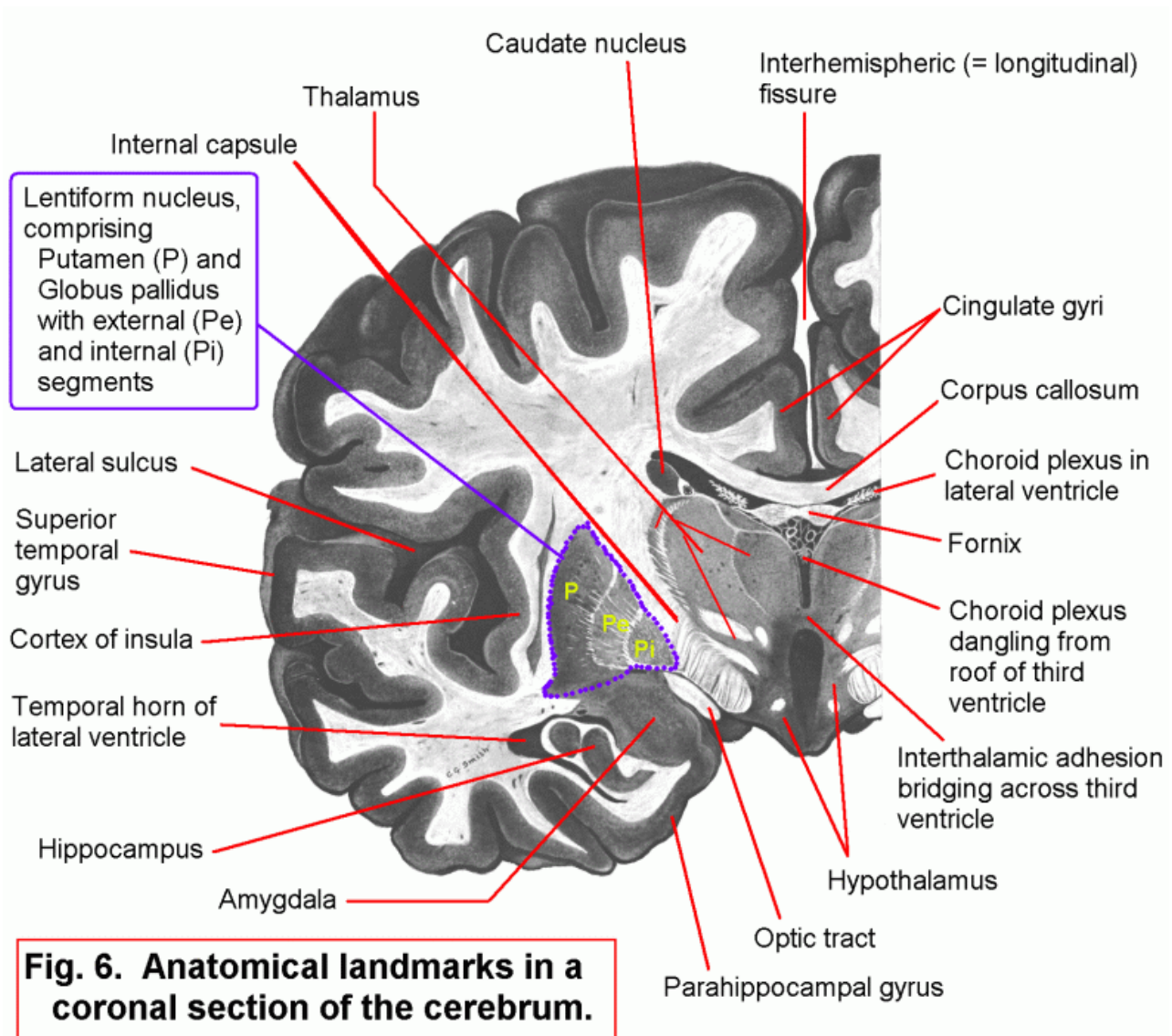

Only one large body of white matter links brain stem and diencephalon with the cerebral cortex. This is the **internal capsule** (Fig. 6). It consists largely of ascending thalamocortical fibers and fibers descending from the cortex to the brain stem and spinal cord. The posterior limb of the internal capsule (Fig. 7) includes corticospinal, corticobulbar and corticoreticular fibers with important motor functions.

The **telencephalon** ("end-brain") is associated with the lateral ventricle. Its central gray matter, the **corpus striatum** comprises the large **caudate** and **lentiform nuclei**, which will be discussed in connection with the control of movement.

The external surface of the telencephalon is formed by the **cerebral cortex**. Some cortical landmarks are indicated in Fig. 3. The **central sulcus** (fissure of Rolando) and the **lateral sulcus** (sylvian fissure) demarcate **lobes** of the cerebral cortex, which are named for the overlying bones of the skull: **frontal**, **parietal** and **temporal**. The smaller **occipital lobe** forms the posterior pole of the hemisphere, and the **insula** (or insular lobe) is the cortex of the expanded floor of the lateral sulcus (Fig. 7), overlying the lentiform nucleus. Areas of the cortex serve different functions, which have been determined from the effects of lesions, electrical stimulation in the course of surgery, and modern functional imaging techniques. The major functional regions are shown in Fig. 8.

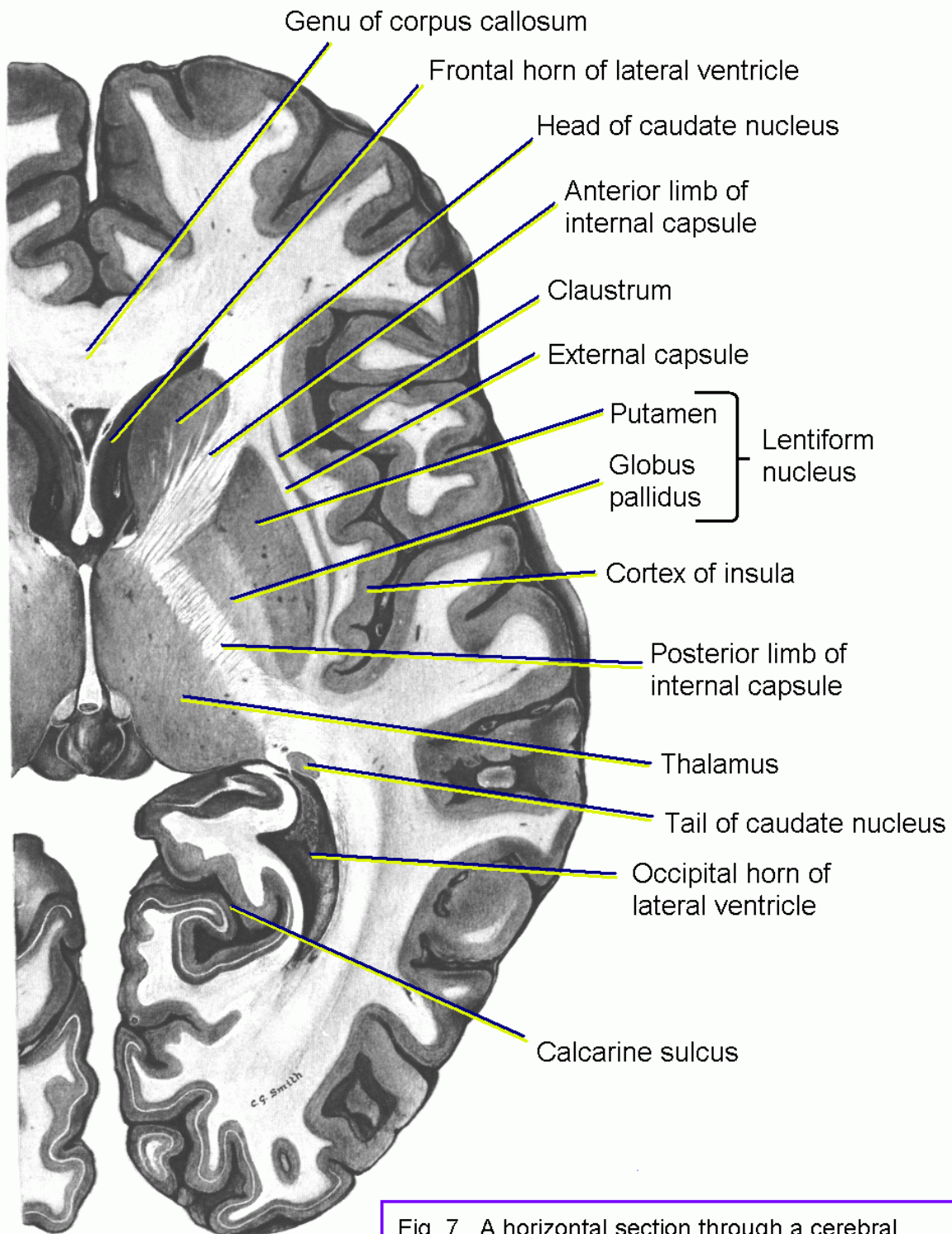

Fig. 7. A horizontal section through a cerebral hemisphere, showing the corpus striatum, internal capsule and thalamus.
 [With permission from Smith CG (1981) *Serial Dissections of the Human Brain*. Toronto: Gage.]

The thick layer of white matter separating the cerebral cortex from the corpus striatum and lateral ventricle contains bundles of fibers of three types. **Association fibers** connect different cortical areas of the same hemisphere. **Commissural fibers** connect the left and right cerebral cortices; most pass through the corpus callosum, but parts of the temporal lobes are connected by the **anterior commissure**. Ascending and descending fibers, connecting the cortex with subcortical regions, are known as **projection fibers**; the internal capsule is a site of concentration of many such fibers.

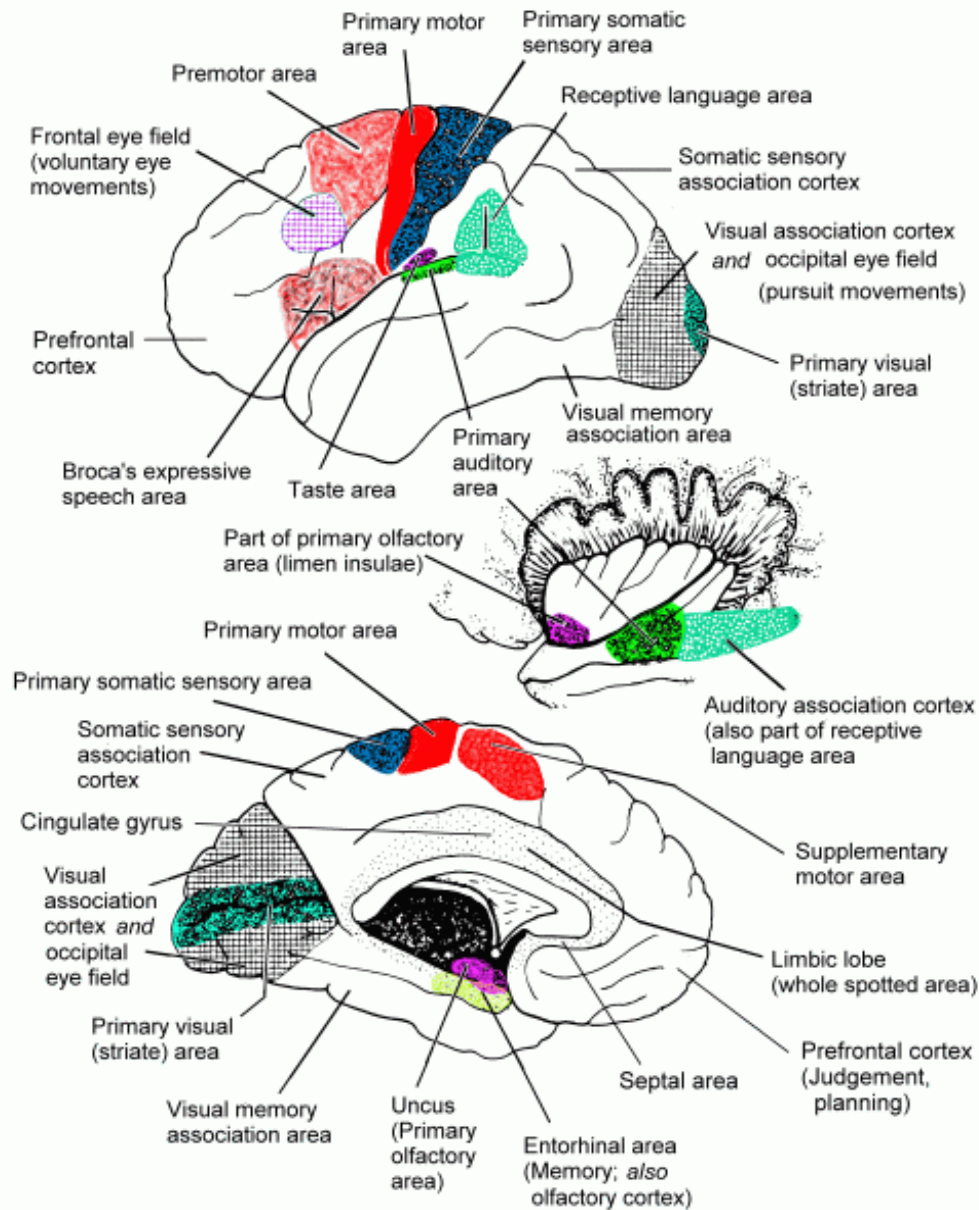
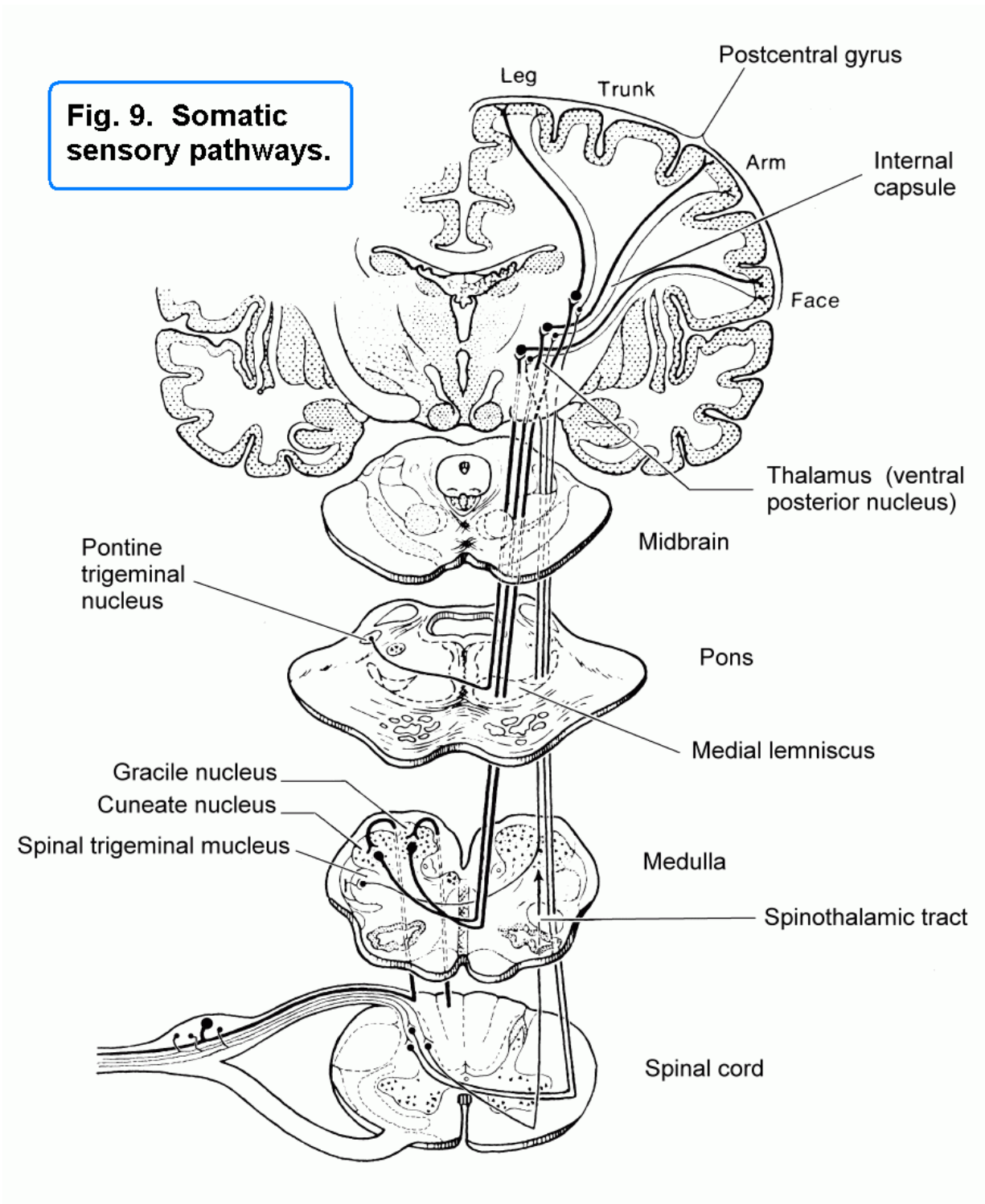

Fig. 8. Cerebral cortex - Functional localization

Functional pathways in the central nervous system

Somatic sensations



Two pathways are involved in conducting general sensory signals to the primary somatosensory area of the cerebral cortex: the **spinothalamic system** (also called the anterolateral pathway), and the **medial lemniscus system** (also called the dorsomedial pathway or the posterior column

system). These are summarized in Fig. 9. The most obvious difference between the two systems is that the spinothalamic tracts cross the midline at segmental levels of the spinal cord, whereas the decussation of the medial lemnisci is in the caudal part of the medulla. Somatic sensory pathways from the head, which enter the brain stem mainly by way of the trigeminal nerve, are also shown in Fig. 9.

Simple touch, temperature and pain

The spinothalamic system (and also the pathway from the spinal trigeminal nucleus shown in Fig. 9) are for the less discriminating sensations. These include the detection but not the detailed evaluation of stimuli impinging on the surfaces of skin and mucous membranes, and pressure that is sufficient to stimulate receptors in deeper tissues. Recognition of non-injurious variation in temperature (tested with warm and cool objects) is carried exclusively in this system. The spinothalamic tract is also the principal, but not the only ascending pathway conducting signals that are felt as pain. Surgical transection of the ventrolateral quadrant of the spinal cord abolishes the ability to experience pain on the opposite side of the body caudal to the lesion. If the patient survives for more than a few months the pain may return, poorly localized but often with greater severity than before. Evidently other ascending pathways can be recruited to detect painful stimuli in the absence of the spinothalamic tract.

Discriminative touch

The **two-point discrimination** test provides the simplest clinical assessment of the integrity of the medial lemniscus system, but transection of the dorsal column or medial lemniscus causes only a partial impairment of the detection of simultaneously touched sites. A more specific test seeks the identification of changes in orientation as well as spatial separation. This is most easily done by asking the patient to recognize a simple shape, such as a triangle or a letter, drawn on the skin with the examiner's finger or a smaller blunt instrument. The recognition of shapes requires also the integrity of the somatic sensory cortical areas of the parietal lobe. Detecting the **vibration** of a low frequency tuning fork applied to a bony prominence is a simple test often wrongly associated with the medial lemniscus system. Vibration can be felt when the dorsal columns have been completely transected; the test has no localizing value for spinal lesions, but it is useful for showing the integrity of the fastest-conducting peripheral sensory fibres.

Proprioception

The conscious perception of position and movement originates principally in the muscle spindles, which are receptors that report the lengths (and also changes in lengths) of muscles. There are also receptors that detect mechanical conditions in tendons and joints, but their signals are probably used mainly for spinal reflexes and cerebellar activity, without conscious awareness. For the **upper limb**, conscious proprioception is mediated by the medial lemniscus system, which includes axons that ascend in the cuneate fasciculus (see Figs 4, 9). The equivalent pathway from the **lower limb** is only partly through the gracile fasciculus and nucleus; there is an additional pathway, located more laterally in the spinal cord. Some axons of lumbosacral proprioceptive neurons leave the gracile fasciculus and end in the nucleus thoracicus (Clarke's column) of the dorsal horn (Fig. 4). This nucleus is the source of the dorsal spinocerebellar tract, which is in the lateral white matter of the spinal cord. Clinical studies of rare lesions confined to the dorsal columns of the cervical cord reveal preservation of conscious proprioception in the lower limbs. Tracing experiments in animals indicate that branches of dorsal spinocerebellar tract axons end in group of neurons (Nucleus Z of Brodal & Pompeiano) just rostral to the gracile nucleus, which sends fibers into the contralateral medial lemniscus. This nucleus exists also in the human brain.

Other proprioceptive connections operate below the level of consciousness. They include synapses in the spinal gray matter (for stretch reflexes), the ventral spinocerebellar tract (Fig. 4)

and the cuneocerebellar tract (upper limb equivalent of the dorsal spinocerebellar tract). Proprioceptive endings occur also in the muscles supplied by cranial nerves; their central connections, however, are not described here.

Voluntary movement: Descending motor pathways

The primary sensory neurons that innervate muscle spindles have axonal branches in the spinal cord (or brain stem) that form excitatory synapses with motor neurons. Rapid stretching of a muscle (by tapping its tendon) evokes a monosynaptic reflex contraction: the **stretch reflex** or **tendon jerk**. Ordinary movements do not elicit this reflex contraction, because it is suppressed by activity in tracts that descend from the brain stem and cerebral cortex. Below the level of a complete transection of the spinal cord, after an initial period of "spinal shock," voluntary movement is impossible and the stretch reflexes are uninhibited. Every passive movement is resisted, and the muscles are in a state of tonic contraction known as **spasticity**. The upper and lower limbs are typically held in flexion.

Three descending tracts from the brain (Fig. 10) are principally responsible for modulating spinal reflexes and providing instructions for skilled and unskilled movements.

The **vestibulospinal tract** arises from certain large neurons in the vestibular nuclei of the medulla. These cells are activated by sensed changes in position and movement of the head, and their axons end in the medial part of the ventral horn of the spinal gray matter. They stimulate contraction of the extensor muscles of the trunk and lower limb, and (in man) the flexors of the upper limb. Transection of descending motor pathways at a level rostral to the medulla causes a spastic paralysis in which the lower limbs are extended, due to unopposed action of the vestibulospinal projection.

Reticulospinal fibers arise from neurons in the medial parts of the reticular formation of the pons and medulla. Their distribution in the spinal cord, deduced from human clinico-pathological studies, is shown in Fig. 4. Neurons in the reticular formation have long dendrites that are contacted by collateral branches of axons ascending and descending through the brain stem. For example, many spinothalamic tract fibers have branches that synapse with reticular formation neurons, and there are also spinoreticular fibers. The motor regions of the reticular formation also receive descending afferents from all the motor areas of the cerebral cortex, providing a disynaptic cortico-reticulo-spinal pathway. Corticoreticular fibers probably do not cross the midline, and most reticulospinal fibers probably decussate in either the brain stem or the spinal cord (Fig. 10).

The disabling "upper motor neuron" spastic hemiplegia that follows destruction of the motor and premotor cortical areas, or transection of descending motor fibers by a lesion in the internal capsule or cerebral peduncle, is probably attributable to loss of the corticoreticular projection. Transection of reticulospinal fibers probably accounts for spasticity due to destructive lesions in the spinal cord or ventral medulla.

The **corticospinal tract** contains the axons of cells in the **primary motor area**, **premotor area** and **supplementary motor area** of the frontal lobe. **Corticobulbar fibers** have similar origins, but end in and around the motor nuclei of cranial nerves V, VII and IX-XII in the pons and medulla. The premotor and supplementary motor areas (Fig. 8) also send association fibers to the primary motor cortex. All the motor areas of the cerebral cortex receive indirect input from the basal ganglia and cerebellum (Fig. 11).

Descending pathways to the motor nuclei of cranial nerves (including **corticobulbar fibers**) are both crossed and uncrossed. The only muscles controlled exclusively by the contralateral cerebral hemisphere are those of the lower half of the face (facial nerve) and the trapezius (accessory nerve). The tongue (hypoglossal nerve) is largely but not exclusively under contralateral control, and the sternocleidomastoid muscle (accessory nerve) is controlled by the

ipsilateral cerebral hemisphere. All other muscles of the head and pharynx, including the upper half of the face, are controlled by both cerebral hemispheres. Consequently, the paralysis due to a lesion in a cerebral hemisphere, such as infarction of the internal capsule or frontal lobe, involves only the lower half of the contralateral side of the face. A facial weakness that also involves the muscles around and above the eye can be due only to a "lower motor neuron" lesion, involving either the facial motor nucleus or its efferent axons in the brain stem or facial nerve.

The eye muscles are not directly controlled by the cerebral cortex, and will be discussed later.

Corticospinal and corticobulbar fibers, accompanied by corticoreticular fibers and corticopontine fibers (which end in the pontine nuclei), descend through the posterior limb of the internal capsule, between the thalamus and caudate nucleus (Fig. 7), and then pass into the ventral part of the cerebral peduncle (Fig. 5). At this level, the corticospinal and corticobulbar fibers are flanked medially and laterally by corticopontine fibers. The location of the corticoreticular fibers in the human midbrain has yet to be discovered. In the ventral pons, the corticospinal tracts form several small fasciculi dispersed among the pontine nuclei and the decussating pontocerebellar fibers. At the caudal border of the pons, the corticospinal fibers reassemble on each side to become the left and right **pyramids** of the medulla (Figs 3, 5). This anatomical landmark accounts for a much misused synonym, **pyramidal tract**. At the caudal end of the medulla, most of the axons in the pyramids decussate and enter the lateral white matter of the spinal cord (Fig. 4). Corticospinal axons end by contacting both interneurons and primary motor neurons in the ventral horn. (The small **ventral corticospinal tract**, composed of uncrossed axons that descend in the ventromedial spinal white matter, is not shown in Fig. 4 or Fig. 10. Very rarely, this ventral tract is larger than the crossed **lateral corticospinal tract**.)

Physiological studies in monkeys and clinicopathological investigations of certain rare human lesions indicate that the corticospinal tracts are essential for skilled movements of the hands. Selective transection (possible only in the midbrain or medullary pyramid) causes a transient *flaccid* hemiplegia, followed by recovery of all voluntary movements except those requiring collaboration of different fingers. Before about 1955 it was widely believed that the corticospinal tracts mediated most or all of the supraspinal modification of spinal reflexes, and the adjective "pyramidal" was applied to syndromes of spastic paralysis resulting from large destructive lesions in the cerebral cortex or internal capsule. This misguided usage of words is still occasionally seen in clinical case reports. The term "upper motor neuron paralysis" is more appropriate for the condition in which muscles are hypertonic, with exaggerated stretch reflexes, and cannot be voluntarily used because of transection of descending motor pathways.

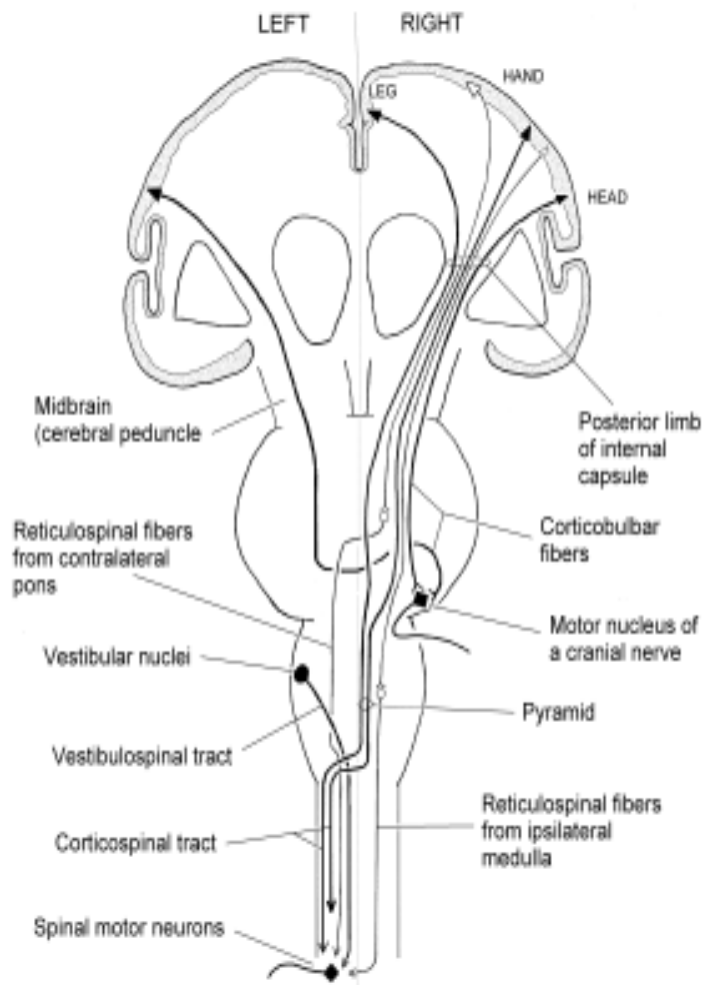

Fig. 10. Descending motor tracts.

A traditional and still valid test of the integrity of the corticospinal or pyramidal tract is the **plantar reflex**. The normal response to a possibly injurious stimulus (plantar flexion) is replaced by a more primitive withdrawal (extension of the hallux, with flexion at the knee and hip: the **Babinski reflex**).

Other circuits for movement

The motor areas of the cerebral cortex cannot control the skeletal musculature without assistance from the cerebellum, which looks after the timing and duration of volleys of impulses in motor neurons, and the basal ganglia, which provide patterns of neuronal activity for learned skills, which are complicated but not directly willed at the time the movements are made.

Cerebellar circuits

The connections of the cerebellum have already been described. In Fig. 11 they are placed in context with descending pathways from the cerebral cortex and the circuitry of the basal ganglia..

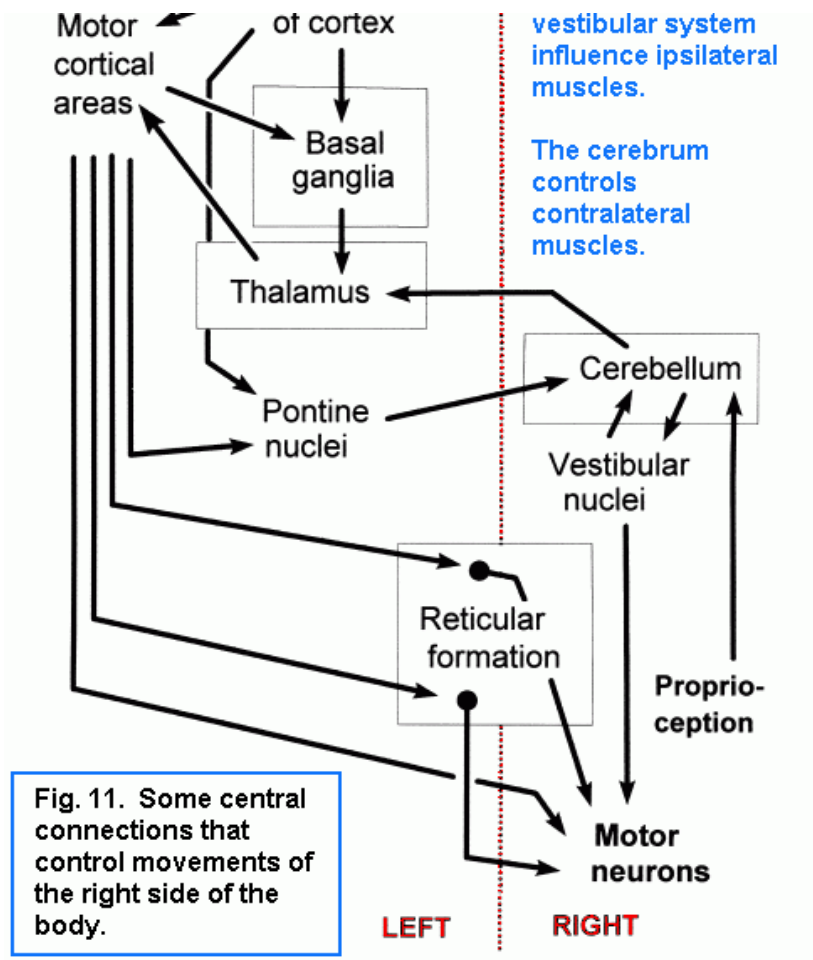

Basal ganglia circuits

The expression "basal ganglia" embraces the corpus striatum (caudate and lentiform nuclei, Fig. 7), the substantia nigra in the midbrain, and the subthalamic nucleus (Fig. 6). The lentiform nucleus comprises adjacent but functionally different parts. The lateral **putamen** and the caudate nucleus constitute the **striatum**. The medial part of the lentiform nucleus (globus pallidus, Fig. 7) is the **pallidum**, which has differently connected external and internal divisions. The circuitry and neurotransmitters of the basal ganglia are quite well understood (Fig. 12), and this knowledge provides a crude understanding of some disorders of the system. For example, destruction of the **subthalamic nucleus** leads to reduced inhibition of the thalamus, which then stimulates the motor cortical areas excessively, causing contralateral **hemiballismus**. A similar argument may account for the poverty of movement in **Parkinson's disease**, which is due to degeneration of the dopamine-producing neurons of the **substantia nigra**.

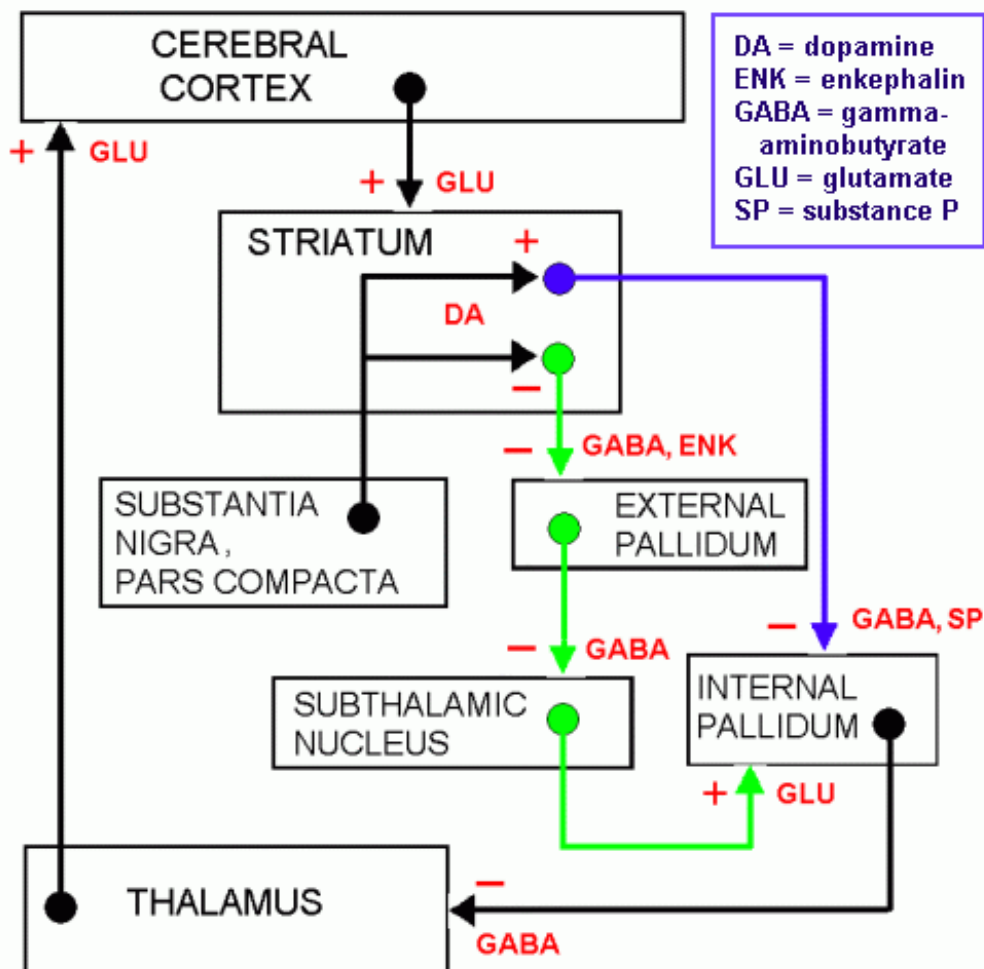

Fig. 12. Circuitry of the basal ganglia, showing neurotransmitters and excitatory (+) and inhibitory (−) actions at synapses.

Eye movements

The neuronal circuits that control movement of the eyes are numerous and complicated, being driven largely by the sensory visual system. Some of these connections are shown in Fig. 13.

Salient features of this system are (1) For **vertical eye movements**, the pathway involves nuclei in the rostral midbrain, and (2) **For horizontal eye movements** the pathway descends to the caudal pons (abducens nucleus, for lateral rectus muscle), then crosses the midline and ascends to the rostral midbrain (oculomotor subnucleus for medial rectus muscle). **Convergence and divergence** of the eyes are regulated mainly at the level of the midbrain and do not require the integrity of the frontal eye field.

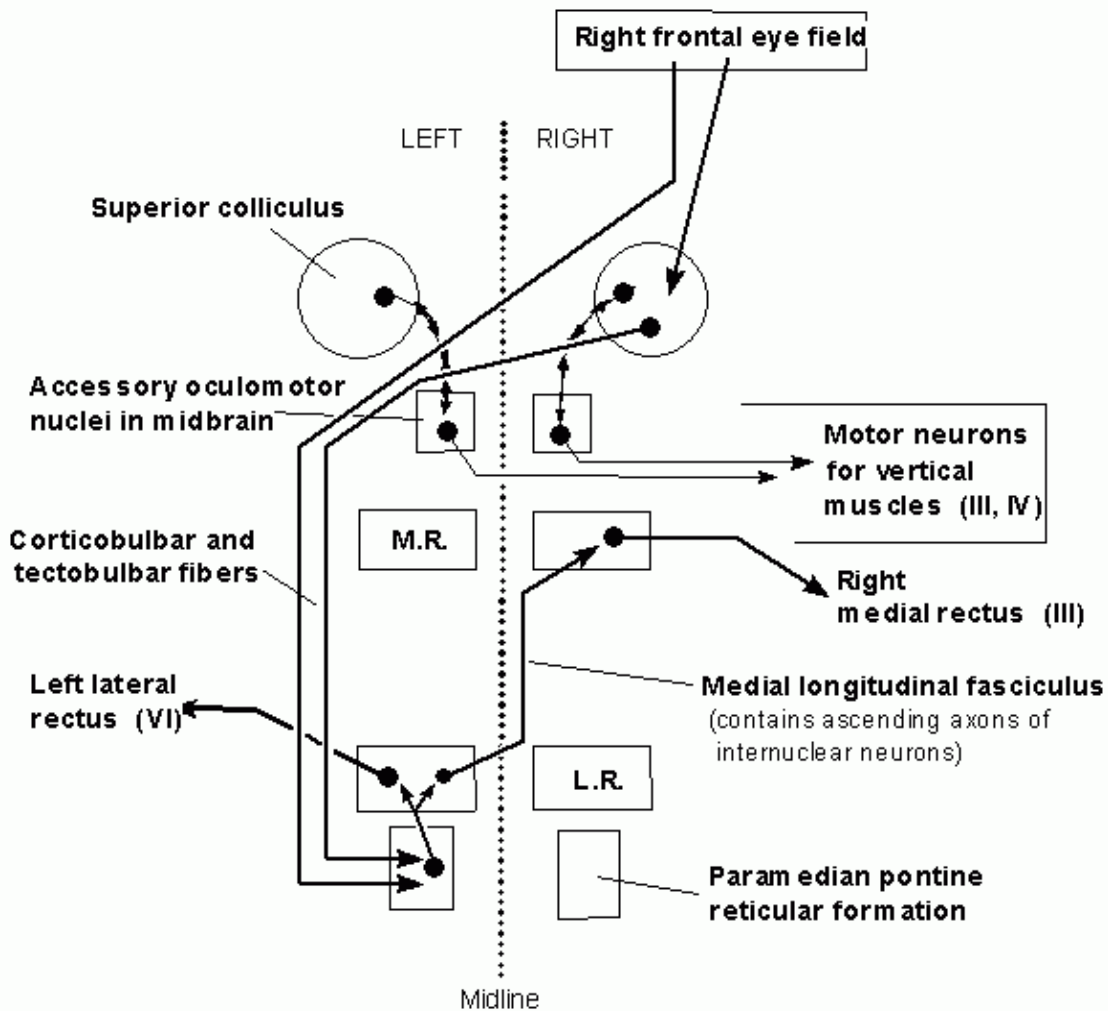

Fig. 13. Some of the neuronal connections that control eye movements, with emphasis on the cortical control of voluntary conjugate gaze to the left. *Abbreviations:* **L.R.** = abducens nucleus, supplying lateral rectus muscle; **M.R.** = subnucleus of oculomotor nucleus supplying medial rectus muscle. Roman numerals (**III, IV, VI**) are for cranial nerves.

Two cortical areas are involved in the control of eye movements. The **frontal eye field** (Figs 8, 13) stimulates rapid shifting of the direction of gaze to the opposite side. Destruction of this cortical area results in a conjugate deviation of the eyes toward the side of the lesion. Pursuit movements (tracking an object moving slowly across the field of vision) are not paralyzed. The **posterior parietal eye field** is the region needed for pursuit. Lesions here also cause visual defects but do not prevent rapid, voluntary eye movements.

Special senses

Equilibration

The **static** vestibular receptors in the utricle and saccule of the inner ear respond to the position of the head in relation to gravity (or other accelerating or decelerating forces), and the **kinetic** receptors in the semicircular ducts report rotational movement of the head in any plane. The primary sensory neurons are in the vestibular ganglion, and their axons enter the brain in the vestibular division of cranial nerve VIII (Table 3). Most end in the four vestibular nuclei, which are beneath the lateral part of the floor of the fourth ventricle; some go directly to the cerebellum in its inferior peduncle. The reciprocal connections of the vestibular nuclei with the vestibular parts of the cerebellum were discussed in the context of the cerebellum, and the vestibulospinal tract was described with the other descending motor tracts (Figs 10, 11).

A poorly understood ascending pathway from the vestibular nuclei to the thalamus and then to the cerebral cortex provides conscious awareness of position and movement as perceived by the receptors in the inner ear. Cortical areas responding to stimulation of the kinetic receptors have been identified at various sites in the parietal and temporal lobes. The principal symptom of abnormal stimulation or inhibition of the vestibular system is **vertigo** associated with nystagmus (see below) and nausea or vomiting. The gastric disturbance is attributed to disrupted connections of the vestibular nuclei with one of the preganglionic parasympathetic nuclei of the vagus nerve. A unilateral destructive lesion in the inner ear, vestibular nuclei or inferior cerebellar peduncle also causes ataxia, with a tendency to fall toward the side of the lesion. This is attributed to unopposed action of the contralateral vestibulospinal tract on motor neurons that supply extensor muscles of the lower limb.

Some neurons in the vestibular nuclei have axons that travel rostrally in the **medial longitudinal fasciculus (MLF)**, both ipsilaterally and contralaterally, and end in the motor nuclei of cranial nerves VI, IV and III. The MLF is adjacent to the midline at all levels of the brain stem. It contains also the axons of neurons used for rapid conjugate eye movements (Fig. 13).

Vestibulo-oculomotor fibers in the MLF mediate the **vestibulo-ocular reflex**, which is a slow conjugate movement of the eyes in a direction opposite to that of a slow rotation of the head through a small angle. The angular movement of the eyes is equal to that experienced by the semicircular ducts, but in the opposite direction. This reflex is disturbed by rapid movements of endolymph in the semicircular ducts, which cause vertigo and back-and-forth eye movements known as **nystagmus**. When nystagmus is due to vestibular stimulation, each cycle of eye movement has a slow component in one direction (driven by the vestibular system) and a fast corrective component (driven by descending pathways; see Fig. 13). In **caloric testing** the kinetic receptors are artificially stimulated by irrigating the external ear with warm or cool water, causing convection currents in the semicircular ducts. The normal response is nystagmus with slow and fast components. In a comatose patient, only the slow component is seen because the fast "voluntary" compensation is suppressed. The eyes move toward the side stimulated by cool water. Absence of this response after bilateral stimulation indicates destruction of the vestibular nuclei, medial longitudinal fasciculi or ocular motor nuclei, and contributes to a diagnosis of brain stem death.

Hearing

Neurons in the spiral ganglion of the cochlea send their axons to the **cochlear nuclei**, which are located on the dorsolateral and ventrolateral aspects of the inferior cerebellar peduncle. The afferents and efferents of the cochlear nuclei are organized according to the frequencies of sounds received by the organ of Corti in the inner ear. The cochlear nuclei project bilaterally to other nuclei in the brain stem, and the pathway ascends bilaterally, with relays in the midbrain and thalamus, to the primary auditory area on the superior surface of the temporal lobe. The

auditory association cortex, necessary for recognition and interpretation of sounds is posterior to the primary area, and in the left hemisphere it includes Wernicke's area, which is part of the receptive language area (Fig. 8).

Unilateral deafness does not occur with transection of the auditory pathway rostral to the cochlear nuclei (rostral medulla), and is therefore attributable to disease of the ear (common) or lesions that impinge on cranial nerve VIII or the inferior cerebellar peduncle (rare). Obstruction of the anterior inferior cerebellar artery can cause unilateral deafness, associated at first with vertigo.

Vision and visual reflexes

The visual pathway

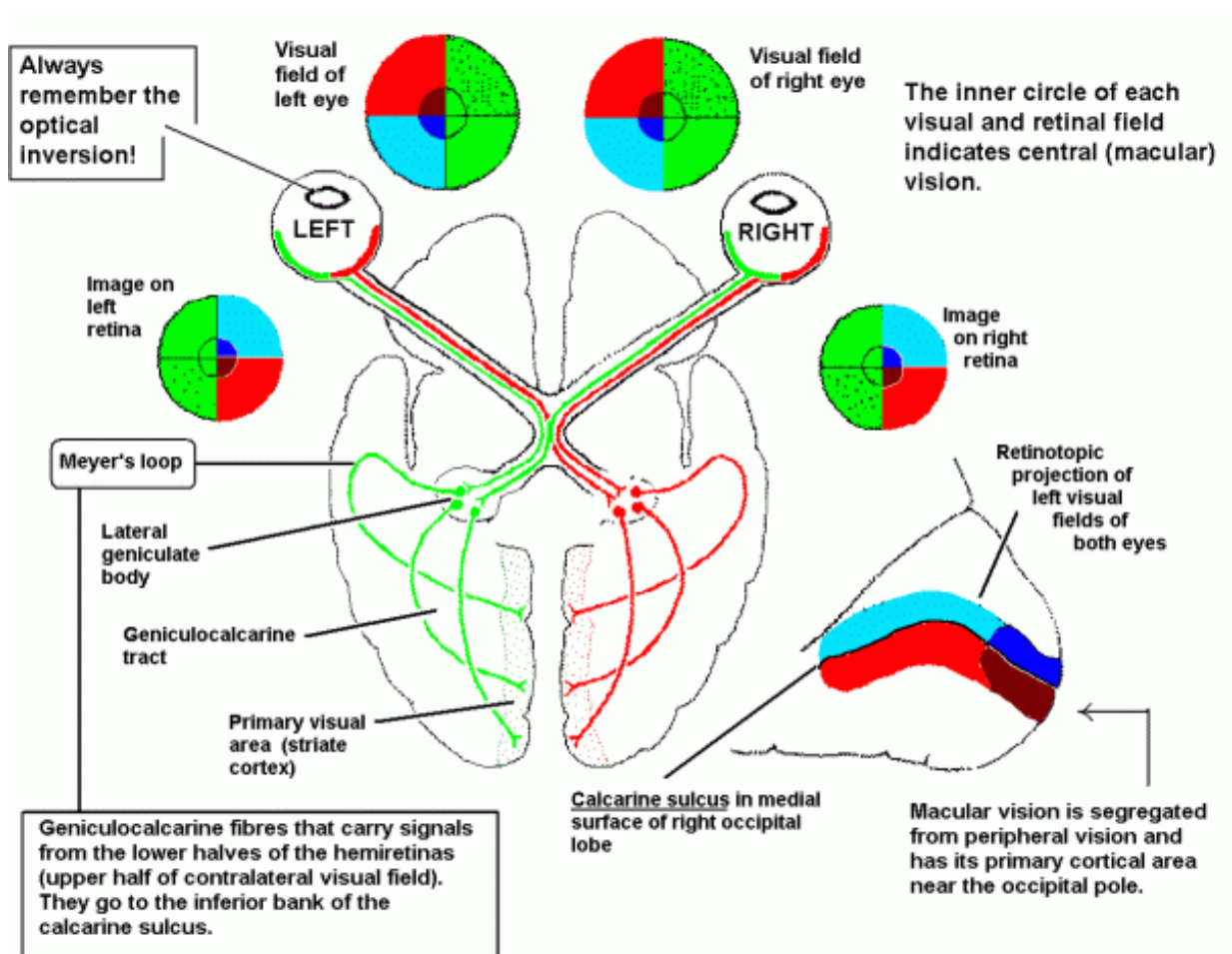

Fig. 14. Retinotopic projection to the primary visual cortex.

There is a topographical projection of the visual field throughout the pathway from the **retina** to the primary visual cortex, which is in and adjacent to the **calcarine sulcus** (Fig. 8). Partial decussation in the **optic chiasma** ensures that axons from the medial half of each retina cross the midline and project to the contralateral cerebral hemisphere, whereas the lateral half of the retina projects ipsilaterally. This arrangement ensures that for each eye signals from the left or right visual field are sent to the contralateral thalamus and cerebral cortex (see Fig. 14).

A unilateral lesion that interrupts the visual pathway posterior to the optic chiasma will cause

blindness in the contralateral visual fields of both eyes. The thalamocortical fibers that loop into the temporal lobe (**Meyer's loop**, Fig. 14) carry signals that originated in the lower halves of the ipsilateral hemiretinas. A destructive lesion in a temporal lobe may therefore cause (among other symptoms) blindness in the contralateral upper quadrants of the visual fields. Small cortical lesions can separately involve the central and peripheral visual field. Larger lesions (such as occlusion of a posterior cerebral artery) affect the whole contralateral field, sometimes with **sparing of central vision** attributable possibly to an accessory blood supply to the occipital pole.

Pupillary light reflex

Not all the axons of the optic tract end in the thalamus. Some go to the **superior colliculus** of the midbrain, and others go to the **pretectal area**, which is rostral to the superior colliculus. When a bright light is shone into one eye, signals are sent into both optic tracts and to the pretectal areas of both sides. Pretectal neurons have axons that synapse with the preganglionic parasympathetic nucleus of the **oculomotor nerve**. Again the projection is bilateral, because some of the fibers cross in the posterior commissure, which is rostral to the pretectal area. The parasympathetic (Edinger-Westphal) nucleus sends axons to the **ciliary ganglion**, which is in the orbit, and the neurons in the ciliary ganglion have axons that travel in the short ciliary nerves to supply the **sphincter pupillae** muscle of the iris. When one retina is illuminated both pupils normally constrict. The contralateral ("consensual") response is mediated by the decussating fibers in the optic chiasma and posterior commissure. The dilator pupillae muscle is supplied by postganglionic sympathetic fibers. These are the axons of cells in the superior cervical ganglion, and they eye by way of the carotid plexus and the long ciliary nerves.

Accommodation for near vision

When the eyes converge to look at a near object, the **ciliary muscle** contracts, allowing the lens to thicken. This shortens the focal length of the refracting media of the eye and allows an image to be sharply focused on the retina. At the same time the pupil constricts, so that the peripheral zone of the lens, which could introduce optical aberrations, is not used. The ciliary muscle, like the sphincter pupillae, is supplied by the ciliary ganglion. The central pathway for accommodation of the lens and pupil differs, however, from that of the pupillary light reflex. Signals pass from the retinas to the superior colliculi and then to the Edinger-Westphal nucleus. The pretectal area does not form part of the pathway for accommodation. Convergence and divergence movements of the eyes are regulated by connections of the superior colliculi and other nuclei in the midbrain.

The different circuits for the light reflex and accommodation may account for the **Argyll Robertson pupil**. This is smaller than normal, in an eye without visual impairment, and it constricts with accommodation but not in response to light. The selective loss of the light reflex can be explained by a lesion in the pretectal area.

Smell

The primary olfactory neurons are the **receptor cells** in and near the roof of the nasal cavity. They are regularly replenished from a population of stem cells in the epithelium, and axons of the new cells grow into the brain and form synaptic connections there. They are the only mammalian neurons that can do this. The unmyelinated axons of the receptor cells gather together in the submucosal connective tissue to form about 20 **olfactory nerves** on each side. These nerves pass through the small holes in the cribriform plate of the ethmoid bone, pierce the dura and other meninges, and then spread out over the surface of the **olfactory bulb**, which lies above the cribriform plate and beneath the medial part of the orbital surface of the frontal lobe.

The primary olfactory axons enter the bulb and terminate in complex synaptic arrangements

around the dendrites of large neurons known as mitral cells. Many other neurons in the olfactory bulb contribute to these synaptic complexes and contribute to the interpretation of the signals initiated by the multitude of airborne chemical stimuli. The axons of the mitral cells enter the **olfactory tract**, which blends with the main mass of the forebrain in the region lateral to the optic chiasma. The fibers of the olfactory tract end in (a) the **uncus**, which is the most medial part of the inferior surface of the temporal lobe, at the anterior end of the parahippocampal gyrus, (b) the medial part of the **amygdala**, which is a group of nuclei inside the temporal lobe, between the uncus and the temporal horn of the lateral ventricle, (c) a small part of the **insula** adjacent to the uncus, (d) the posterior part of the inferior surface of the frontal lobe, on the opposite side of the lateral sulcus from the uncus, and (e) in the **entorhinal area**, which is the anterior end of the parahippocampal gyrus. The entorhinal area also receives association fibers from olfactory areas (a) to (d), and it has important connections with the hippocampus and other parts of the brain involved in memory.

Loss of the sense of smell (**anosmia**) is usually due to disease in the nose, but it can also follow head injury, with transection of the olfactory nerves at the level of the cribriform plate. Excitatory lesions in the medial part of the temporal lobe cause olfactory hallucinations and form part of the aura of **uncinate attacks**, a form of temporal lobe epilepsy named from the early involvement of the uncus.

Taste

The receptor cells of taste buds have synapse-like connections with neurons whose cell bodies are in the sensory ganglia of cranial nerves VII, IX and X (Table 3). The central projection is to the **gustatory nucleus**. This is the rostral part of the **solitary nucleus**, a column of cells that extends through the length of the medulla. The neurons in the gustatory nucleus have axons that ascend ipsilaterally in the brain stem; they end in a thalamic nucleus that projects to a cortical area below and just behind the lower end of the primary somatic sensory area (Fig. 8). This **gustatory cortex** extends onto the **insula**, which is a cortical region involved in olfactory, gustatory and autonomic functions.

Loss of taste sensation (**ageusia**) is not a common complaint but it can occur in middle ear disease, because the chorda tympani nerve carries taste fibers that serve the anterior third of the tongue. Sweet tastes are not perceived, but bitter tastes (detected by receptors on the posterior part of the tongue) are unimpaired. Damage to the facial nerve in the subarachnoid space (as from an acoustic neuroma) also impairs taste sensations from the soft palate, which is supplied by the most proximal branch of the facial nerve.

Language, memory and behavior

The most complex activities of the brain are carried out in the cerebral cortex and in certain connected subcortical structures.

Language and speech

The recognition and interpretation of spoken and written language occur unilaterally, in the left cerebral hemisphere of most people. Association and commissural fibers connect the auditory and visual areas with the posterior part of the superior temporal gyrus (Wernicke's area) and the nearby cortex of the parietal lobe (angular gyrus). Destructive lesions in this **receptive language area** result in **receptive aphasia**: inability to understand speech and writing. This is associated with the production of garbled speech, which also is not understood by the speaker. The production of speech requires the integrity of an **expressive speech area** (Broca's area) in the frontal lobe (Fig. 8), on the same side as the receptive area. Damage to Broca's area leads to **expressive aphasia**, in which the attempt to speak results in an output of meaningless, jumbled words. These are heard and recognized as nonsense by the patient.

Cortical areas in the hemisphere not dominant for language are involved in **prosody**, a combination of tones and emphasis that has emotional and musical content, without which the voice is monotonous. The right hemisphere is also used for **spatial awareness**, including recognition of parts of the body, and for the recognition of unseen objects held in the hand.

Memory

The formation of new memories occurs in the circuitry of the **hippocampus**, which is inside the temporal lobe. Association and commissural fibers connect all the sensory association areas with the entorhinal area (see Fig. 8), and this cortex projects to the hippocampus. Efferent fibers of the hippocampus travel in the fornix to the mamillary body of the hypothalamus, which sends axons to the anterior nuclei of the thalamus. This nucleus projects to the anterior part of the cingulate gyrus, on the medial surface of the hemisphere, which is connected by subcortical association fibers with the entorhinal area. The cingulate gyrus, entorhinal area and intervening cortex constitute the **limbic lobe** (Fig. 8), and the hippocampus and connected parts of the brain form part of a "limbic system," together with the amygdala and certain nuclei in the brain stem.

Bilateral interruption of hippocampal circuitry described above results in loss of the ability to form new memories. Older memories can still be recalled, probably because they are stored diffusely throughout the cerebral cortex. Lesions may be in the entorhinal area and hippocampus (Alzheimer's disease), the fornices (damaged by tumors or surgery) or the mamillothalamic tracts (Korsakoff's psychosis). The hippocampi or fornices may also be damaged by separate vascular occlusions, usually of branches of the posterior cerebral arteries.

Amygdala and prefrontal cortex

The amygdala is a group of nuclei in the anterior part of the temporal lobe. Its olfactory afferents have already been mentioned. Other nuclei in the amygdala have extensive two-way connections with the prefrontal cortex (the frontal pole and the orbital surface of the frontal lobe), and with the cortex of the temporal lobe. There are also descending connections of the amygdala with the hypothalamus, epithalamus and several nuclei of the brain stem associated with the autonomic nervous system and other involuntary functions.

Electrical stimulation of the human amygdala causes feelings of fear. Destructive lesions of the temporal lobe that involve the amygdala result in docility, flattened emotional responses and sometimes, in males, increased or perverted sexual activity.

The functions of the prefrontal cortex have been deduced largely from the consequences of brain injuries, surgery (prefrontal leukotomy) and degenerative disease (neurosyphilis, Pick's disease). Lesions must be bilateral to affect behavior. The patients become rude, inconsiderate of others, and unable to foresee the consequences of their actions. These changes in personality and behavior indicate that the prefrontal cortex is involved in the planning of complex activities and making of decisions. Medial frontal lobe lesions, especially if they involve the anterior end of the cingulate gyrus (Fig. 8) can cause **aboulia**, a loss of motivation and willpower. Larger bilateral medial frontal lesions result in **akinetic mutism**. A small infarct in one caudate nucleus can also cause aboulia.