

Lesson 7

Case Studies

You Will Learn Instrumentation for:

- **A. Monitoring synthetic procedure *in situ***
 - **B. Electrochemistry**
 - **C. Spectroelectrochemistry**
-
- **As well as data treatment and presentation**

A. Monitoring synthetic procedure *in situ*

It is known that the smaller the size of the nanoparticle, the shorter the wavelength they absorb. ---**Quantum Confinement** (<http://pubs.acs.org/cgi-bin/archive.cgi/jacsat/1993/115/i19/pdf/ja00072a025.pdf>)

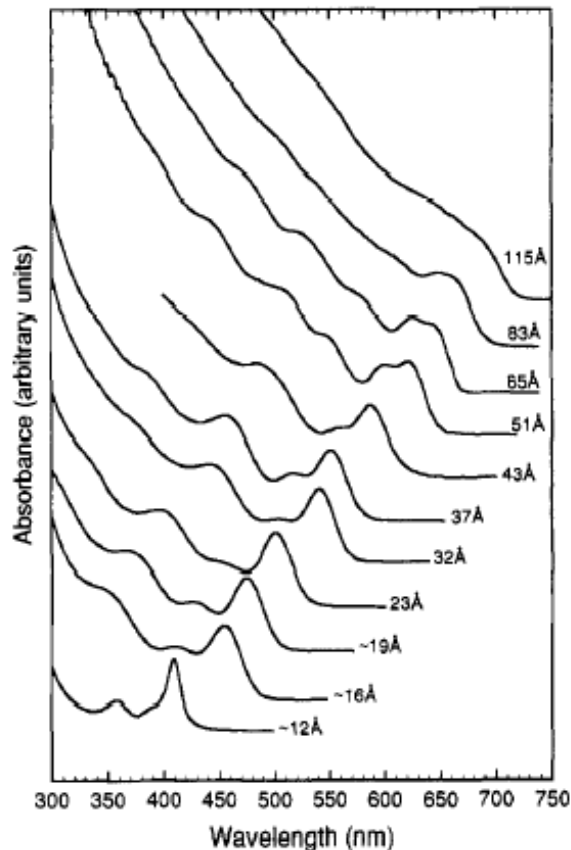
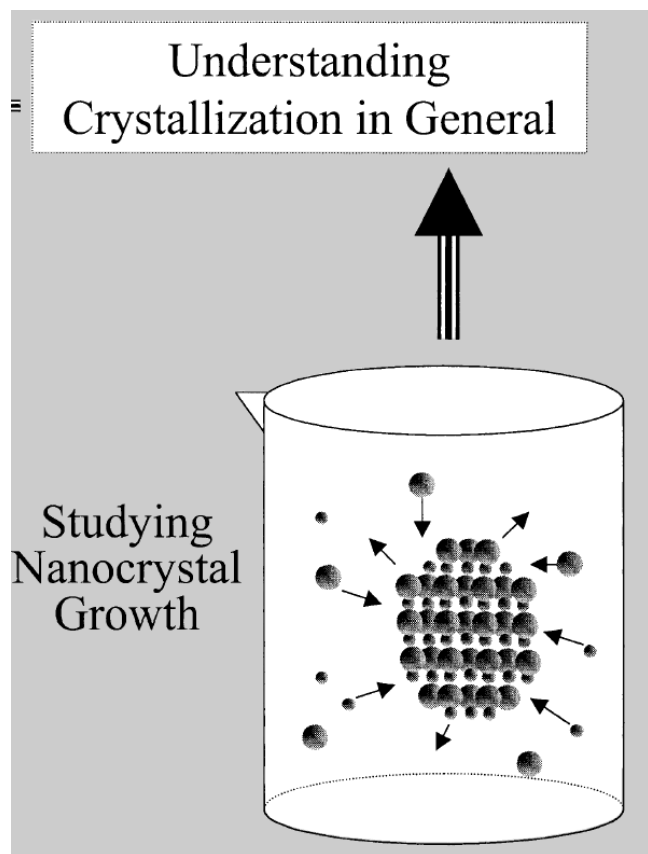
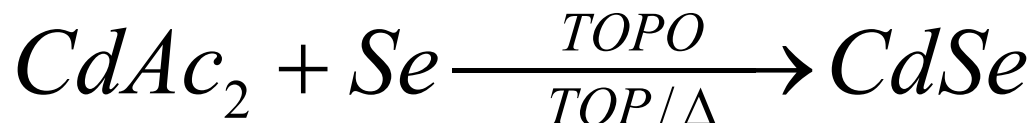

Figure 3. Room temperature optical absorption spectra of CdSe nanocrystallites dispersed in hexane and ranging in size from ~12 to 115 Å.

C. B. Murray, D. J. Norris, M. G. Bawendi, "Synthesis and characterization of nearly monodisperse CdE (E = sulfur, selenium, tellurium) semiconductor nanocrystallites", *Journal of the American Chemical Society* 115 (1993) 8706-8715.

Preparation of monodispersed CdSe nanoparticles is desirable. Peng et al reported that these nanocrystals can be made in a benign way:



L. Qu, X. Peng, "Control of Photoluminescence Properties of CdSe Nanocrystals in Growth", *Journal of the American Chemical Society* 124 (2002) 2049-2055.

L. Qu, W. W. Yu, X. Peng, "In Situ Observation of the Nucleation and Growth of CdSe Nanocrystals", *Nano Letters* 4 (2004) 465-469.

(<http://pubs.acs.org/cgi-bin/asap.cgi/nalefd/asap/html/nl035211r.html>)

Post-measurements by Peng et al in 2002

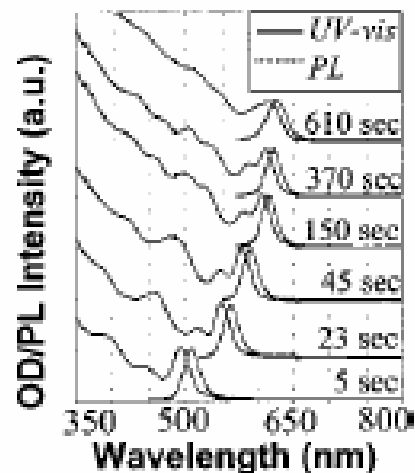
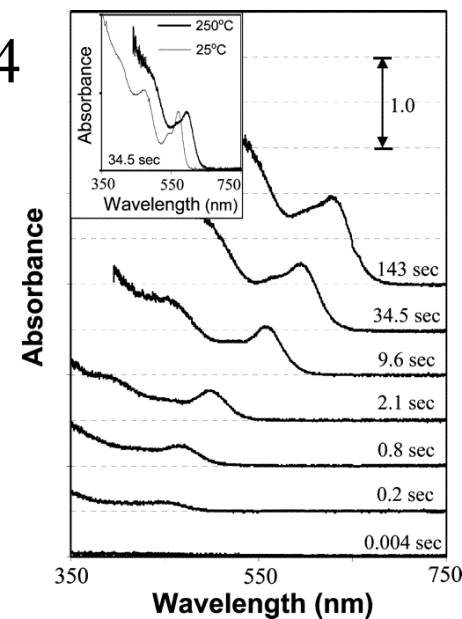
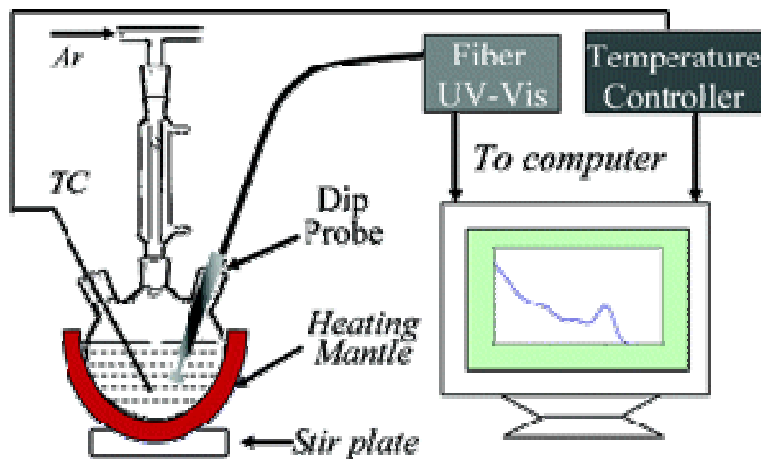

Figure 1. Temporal evolution of UV-vis and PL spectra of a growth reaction of CdSe nanocrystals. See the typical synthesis for details.

In-situ control and measurements by Peng et al in 2004



Instrumentation:

A dip probe immersed in the reaction solution can be connected with a cost-effective hand-held spectrometer (From [Ocean Optics Inc](#) or [Aventes](#)), to monitor the UV-VIS absorption spectrum with LabVIEW and to watch absorption peak wavelength shifting from shorter wavelength to longer wavelength, i.e. the particle size becomes larger and larger.

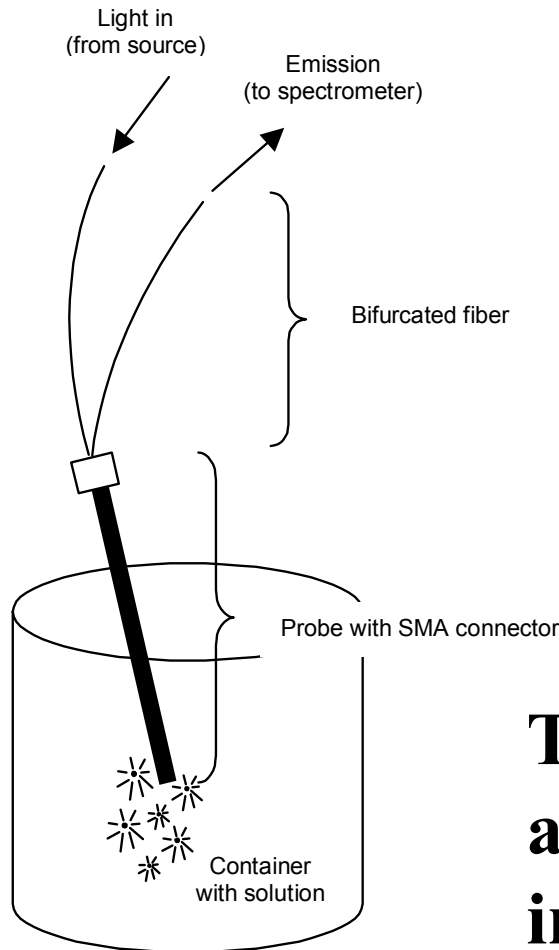

A lamp and a spectrometer interfaced by LabVIEW can be connected.

At desired wavelength (i.e. desired size), the reaction can be stopped.

The same principle can be applied for a dip probe in situ infrared spectrometer.

B. Electrochemistry at liquid/liquid interfaces

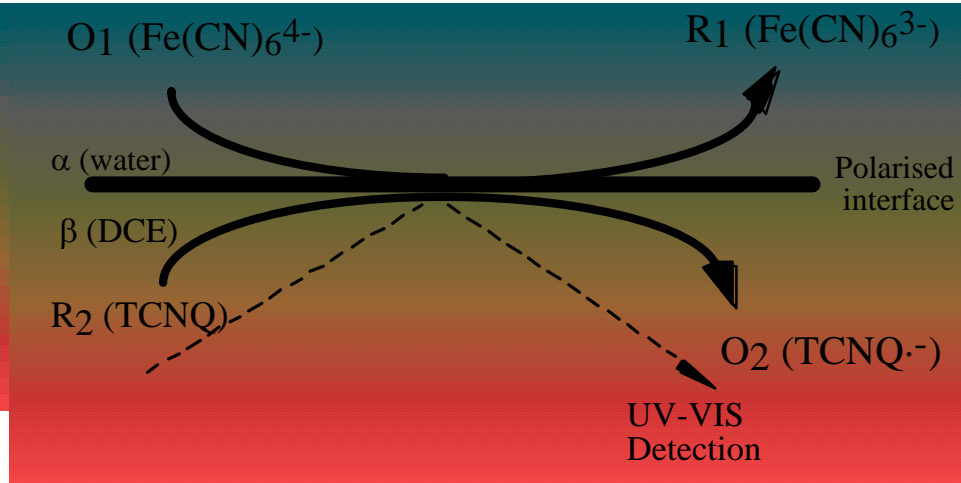
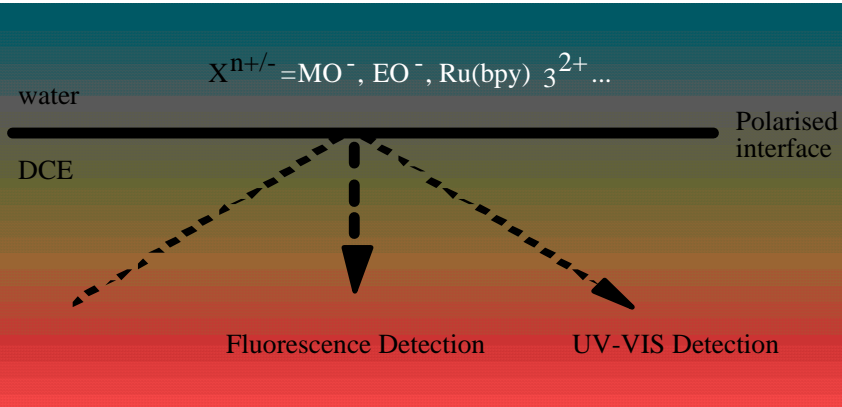

Thermodynamics of Ion Transfer

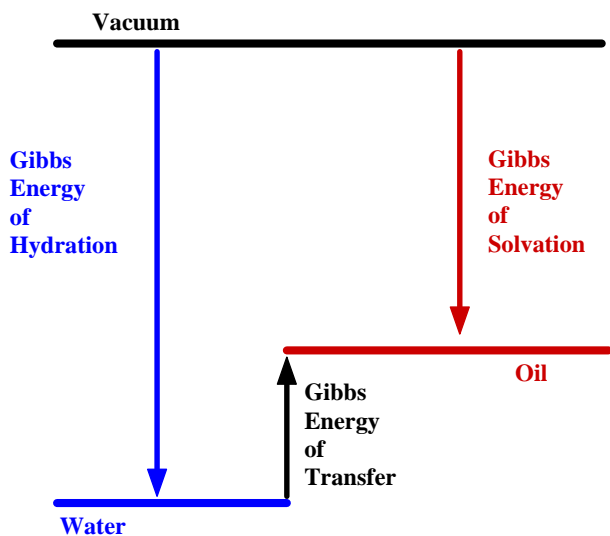

Gibbs Energy of Transfer

$$\Delta G_{tr,i}^{O,W \rightarrow O} = \tilde{\mu}_i^O - \tilde{\mu}_i^W$$

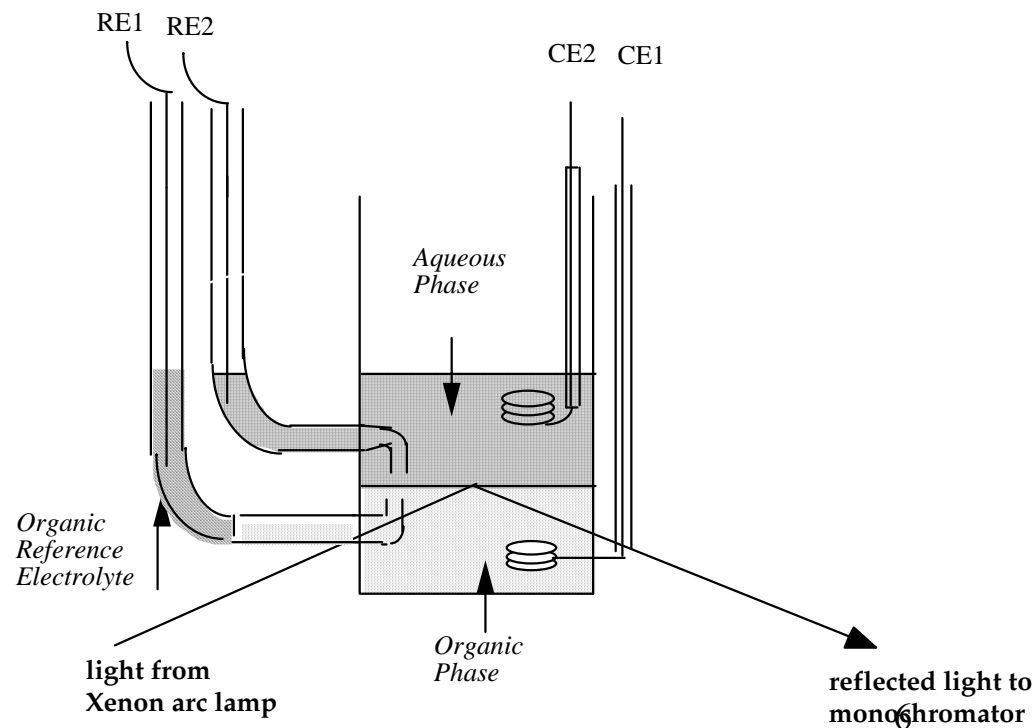

C. Spectroelectrochemistry

1. Introduction

The absorbance of species in solution measured by reflection can be estimated by integration of the Beer-Lambert expression over the distance (x) from the reflecting surface,

$$A^{\text{TIR}} = 2\varepsilon \int_0^{\infty} \frac{c(x)}{\cos\theta} dx \qquad \int_0^{\infty} c(x, t) dx = \frac{1}{zFS} \int_0^t I(\tau) d\tau$$

where θ is the angle of incidence of the light beam at the interface, ε is the molar absorption coefficient of the transferring ion in the phase of higher refractive index and $c(x)$ its concentration at a distance x from the interface.

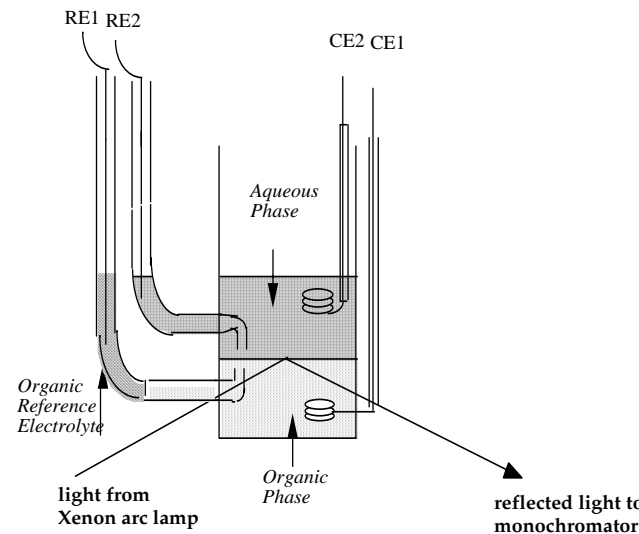

Theory of in-situ UV-VIS and Fluorescence Spectroscopies

$$A^{\text{TIR}} = \frac{2\varepsilon}{zFS \cos\theta} \int_0^t I(\tau) d\tau$$

$$F^o = \frac{2\varepsilon\Phi I_{\text{incid}}}{zFS \cos\theta} \int_0^t I(\tau) d\tau$$

$$\frac{dA^{\text{TIR}}}{dt} = \frac{2\varepsilon}{zFS \cos\theta} I(t)$$

$$\frac{dF^o}{dt} = \frac{2\varepsilon\Phi I_{\text{incid}}}{zFS \cos\theta} I$$

2. Instrumentation:

Instruments: waveform generator+potentiostat+Lamp+spectrometer
or monochromator
PMT

LabVIEW for data acquisition

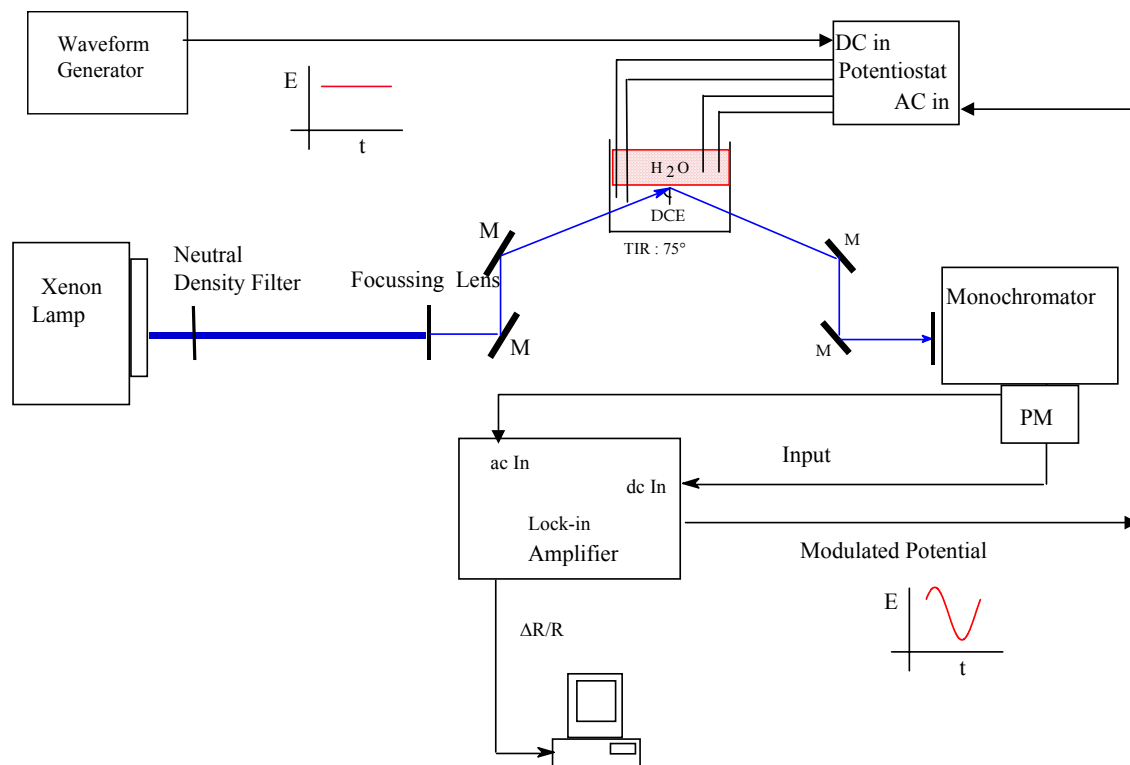

3. Voltabsorptometry on transfer of methyl and ethyl oranges

Z. Ding, F. Reymond, P. Baumgartner, D. J. Fermin, P.-F. Brevet, P.-A. Carrupt, H. H. Girault, "Mechanism and dynamics of methyl and ethyl orange transfer across the water/1,2-dichloroethane interface", *Electrochimica Acta* 44 (1998) 3-13.

http://www.sciencedirect.com/science?_ob=ArticleURL&_udi=B6TG0-3VGV20K-2&_coverDate=09%2F01%2F1998&_alid=152032082&_rdoc=1&_fmt=&_orig=search&_qd=1&_cdi=5240&_sort=d&_view=c&_acct=C000048763&_version=1&_urlVersion=0&_userid=940030&_md5=eae917920b982fc9a0f06cb8880fa607

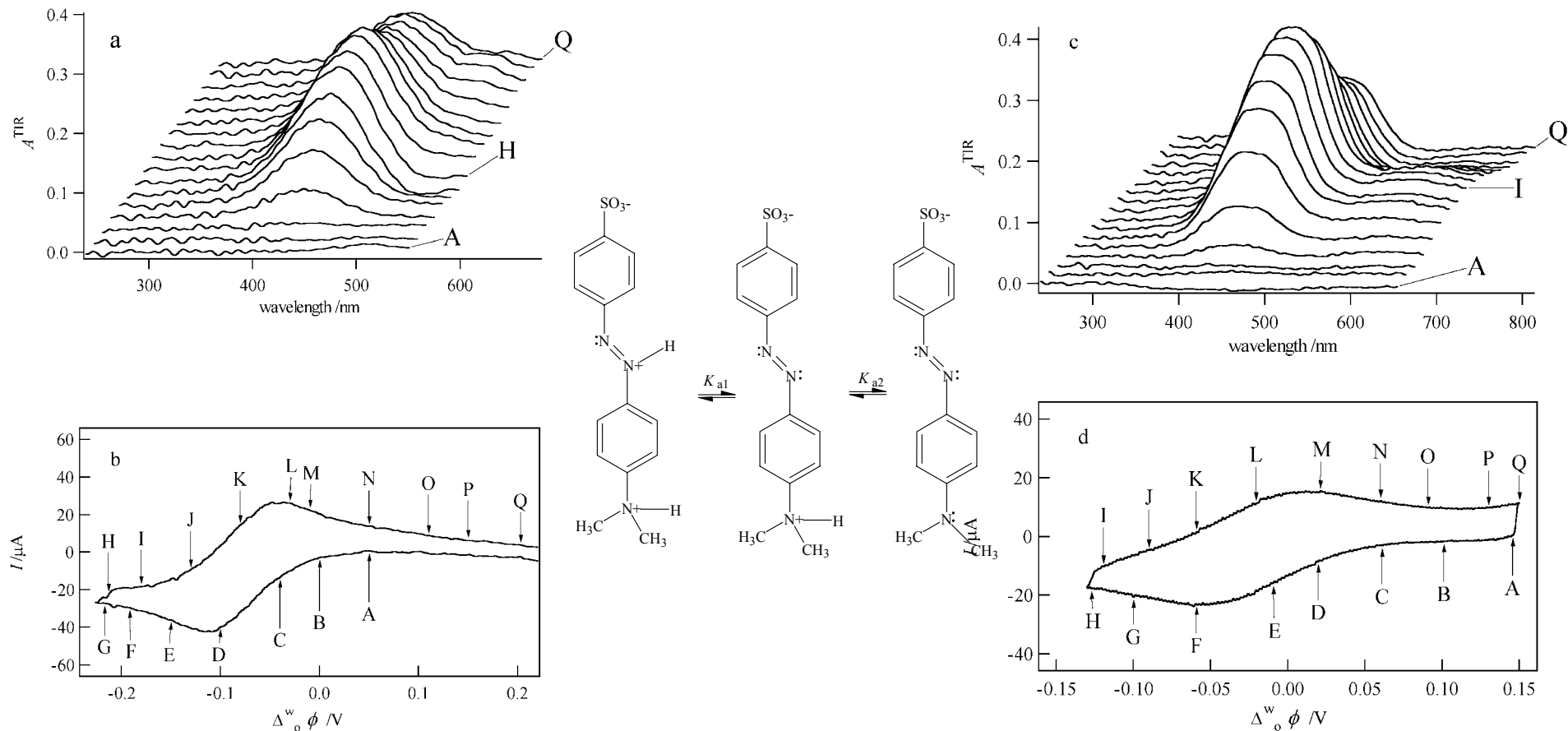

Let's examine SM_SP_EO.vi

SIM_SP_EO.VI

C:\ding\chem532\lesson7\SIM_SP_EO.VI

Last modified on 3/2/2004 at 10:15 AM

Printed on 3/2/2004 at 10:40 AM

Block Diagram

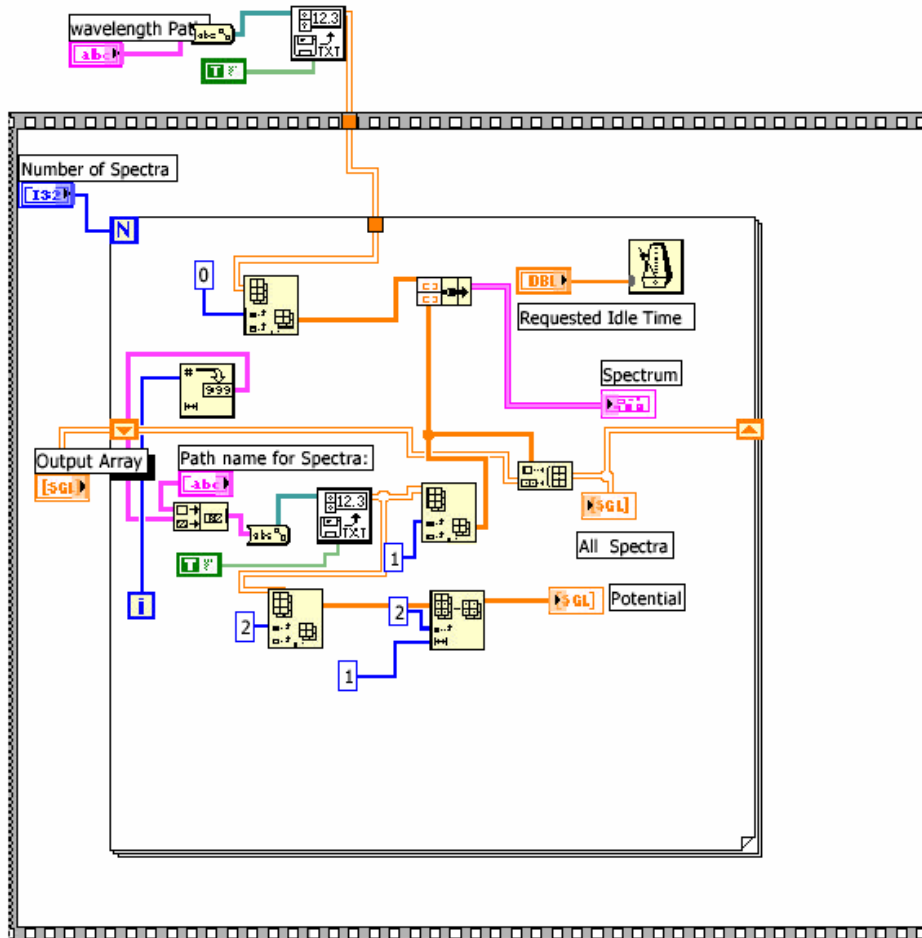

SIM_SP_EO.VI
C:\ding\chem532\lesson7\SIM_SP_EO.VI
Last modified on 3/2/2004 at 10:15 AM
Printed on 3/2/2004 at 10:40 AM

Front Panel

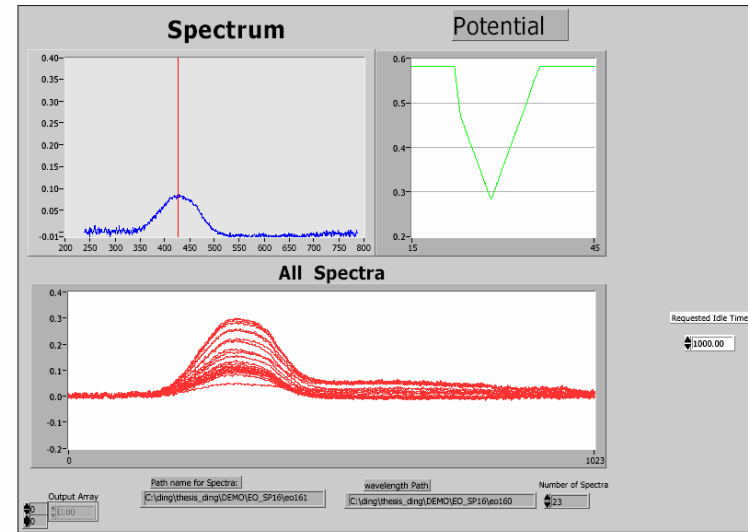

Digestion of the VI

(1). Read From Spreadsheet.vi



(2) How do data flow in LabVIEW----Index Array, Subarray



(3). Concatenated string.vi

Block Diagram

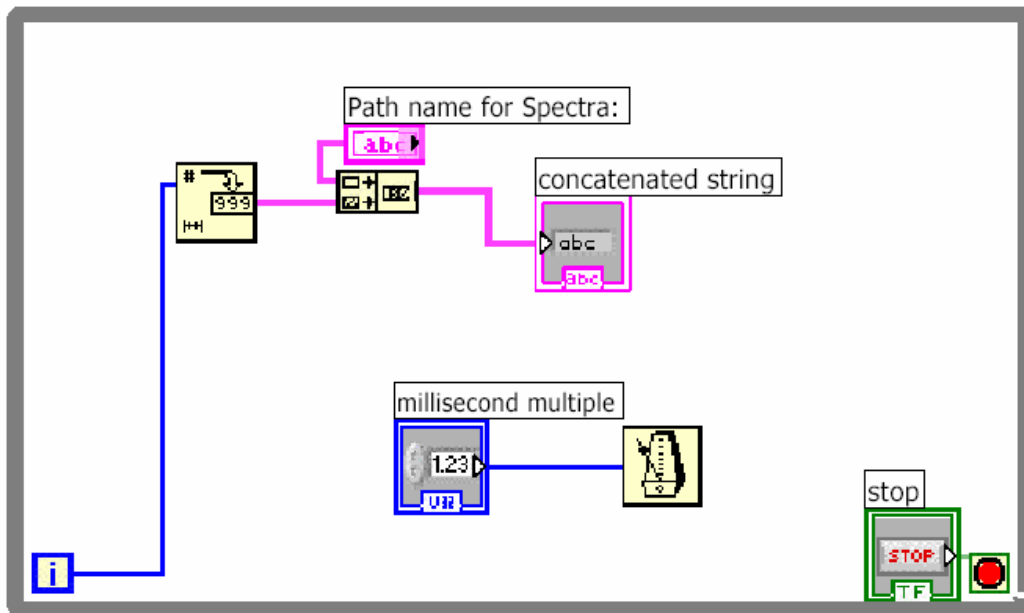

Front Panel

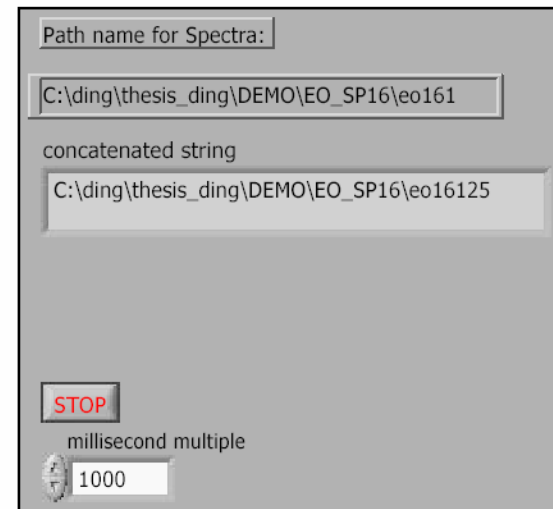

Block Diagram

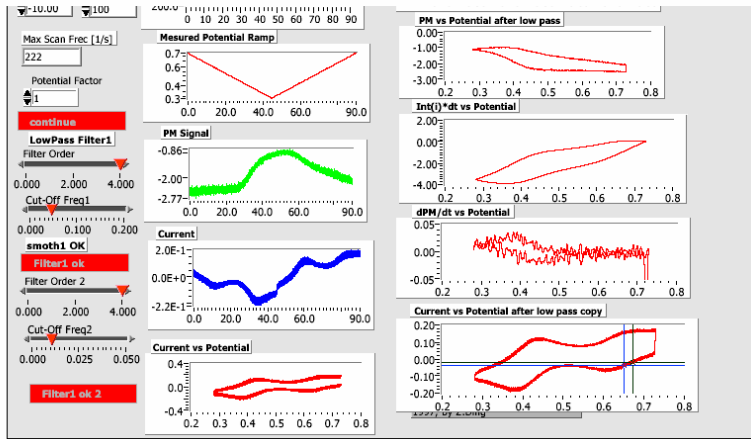
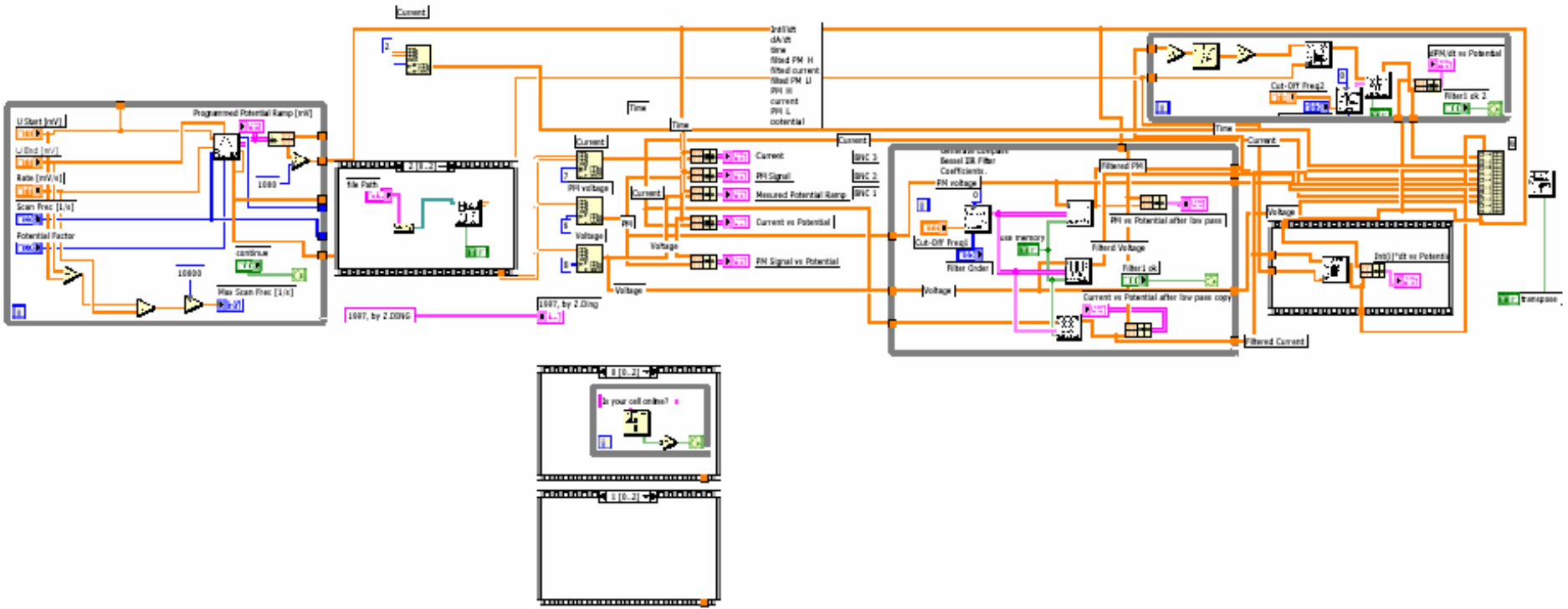

For single wavelength (monochromator +PMT):

(1) How to read a spreadsheet file into LabVIEW



(2) How do data flow in LabVIEW



(3) How to filter out noise in LabVIEW

1. Find the **VI** from **Help»Find Examples...»Search**
2. Type in “**lowpass**” and search
3. Choose **EquiRipple Filter Design.vi**

4. Voltabsorptometry of electron transfer at liquid/liquid interfaces

Z. Ding, P. F. Brevet, "Heterogeneous electron transfer at the polarized water/1,2-dichloroethane interface studied by in situ UV-VIS spectroscopy and differential cyclic voltabsorptometry", *Chemical Communications (Cambridge)* (1997) 2059-2060.

At (<http://pubs.rsc.org/ej/CC/1997/E9705156.PDF>)

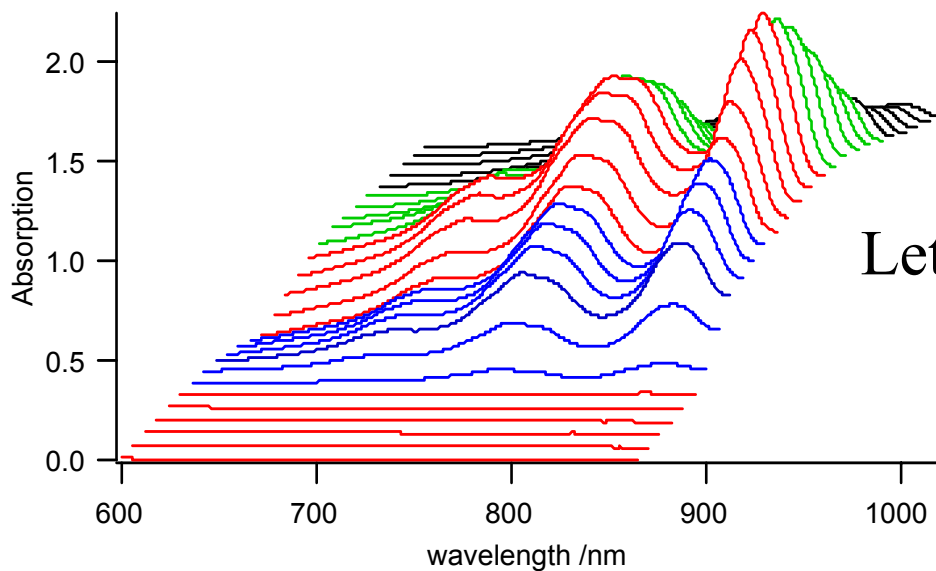
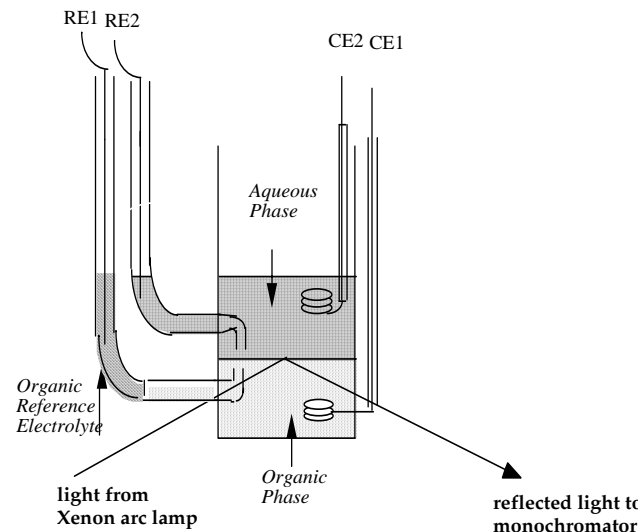
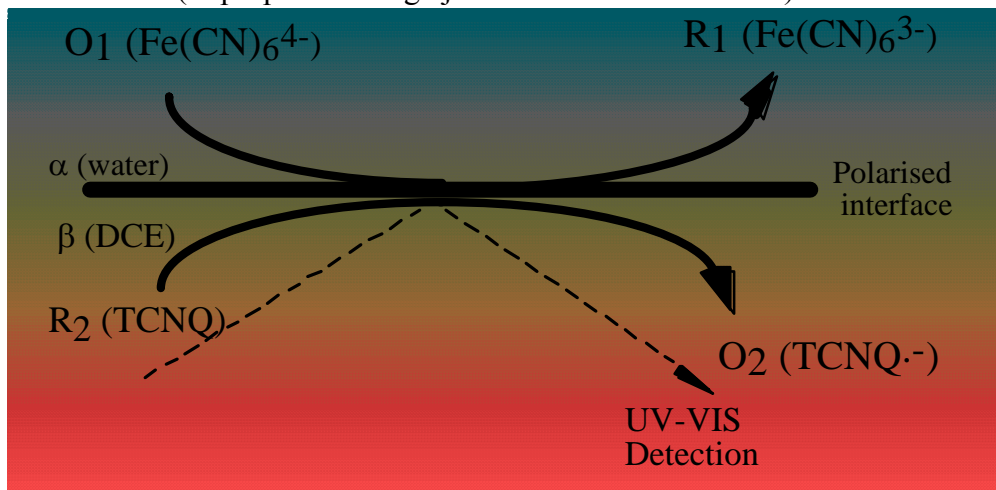

Let's examine SM_SP_TCNQ.vi

References

1. C. B. Murray, D. J. Norris, M. G. Bawendi, "Synthesis and characterization of nearly monodisperse CdE (E = sulfur, selenium, tellurium) semiconductor nanocrystallites", *Journal of the American Chemical Society* 115 (1993) 8706-8715.
2. L. Qu, X. Peng, "Control of Photoluminescence Properties of CdSe Nanocrystals in Growth", *Journal of the American Chemical Society* 124 (2002) 2049-2055.
3. L. Qu, W. W. Yu, X. Peng, "In Situ Observation of the Nucleation and Growth of CdSe Nanocrystals", *Nano Letters* 4 (2004) 465-469.
4. Z. Ding, F. Reymond, P. Baumgartner, D. J. Fermin, P.-F. Brevet, P.-A. Carrupt, H. H. Girault, "Mechanism and dynamics of methyl and ethyl orange transfer across the water/1,2-dichloroethane interface", *Electrochimica Acta* 44 (1998) 3-13.
5. Z. Ding, P. F. Brevet, H. H. Girault, "Heterogeneous electron transfer at the polarized water/1,2-dichloroethane interface studied by in situ UV-VIS spectroscopy and differential cyclic voltabsorptometry", *Chemical Communications (Cambridge)* (1997) 2059-2060.
6. Z. Ding, D. J. Fermin, P.-F. Brevet, H. H. Girault, "Spectroelectrochemical approaches to heterogeneous electron transfer reactions at the polarized water/1,2-dichloroethane interfaces", *Journal of Electroanalytical Chemistry* 458 (1998) 139-148.

Summary

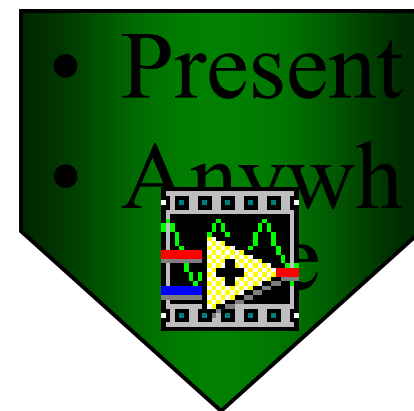
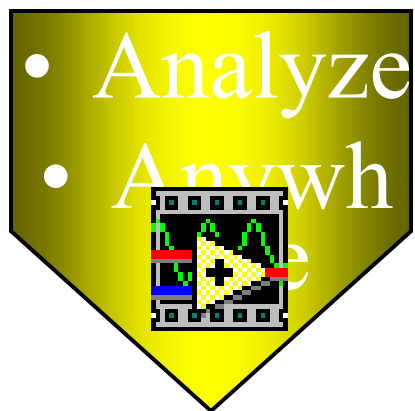
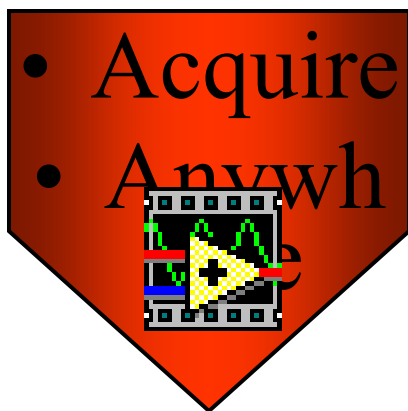

In-situ reaction monitoring, electrochemistry, spectroelectrochemistry can easily be done.