

Lesson 8 Case Studies

You Will Learn Instrumentation for:

- A. Laser photochemistry and photoelectrochemistry
- B. Scanning Probe Microscopy
- C. PID control in chemical engineering
- As well as data treatment and presentation

1

A. Laser photochemistry and photoelectrochemistry (1) Laser photochemistry

a. Principle

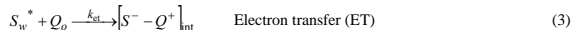
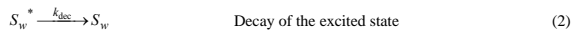
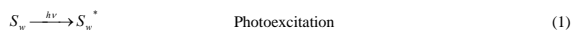
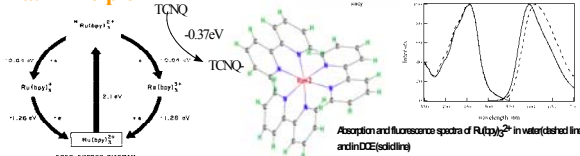

$$\frac{1}{\tau_{\text{app}}} = \frac{1}{\tau_0} + k_q c_q \quad \text{Stern-Volmer Equation to measure ET}_2 \text{ rate}$$

(1) Laser photochemistry

b. Instrumentation

Z. F. Ding, R. G. Wellington, P. F. Erevet, H. H. Gnaull, "Spectroelectrochemical Studies of Ru(bpy)₃Cl₂ at the Water/1,2-Dichloroethane Interface", *J. Phys. Chem. 100* (1996) 10658-10663.

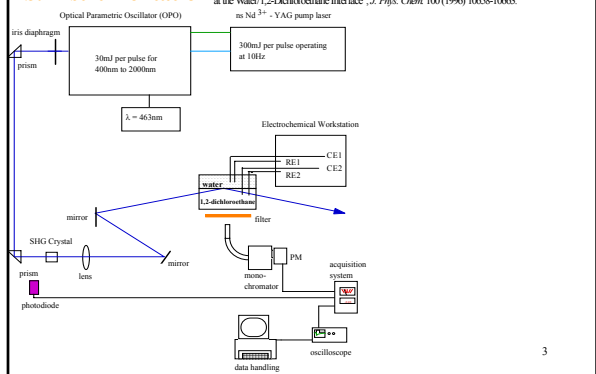

3

(1) Laser photochemistry

b. LabVIEW Data Acquisition

GPIB Oscilloscope driver

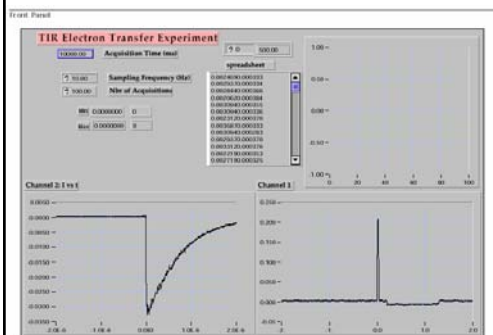

4

Cathode (2) photochemistry-Electrogenerated Chemiluminescence

a. Principle

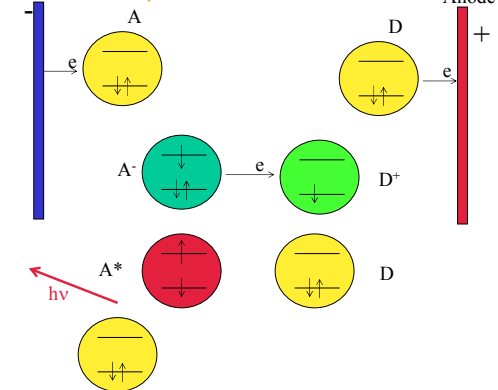

5

Cathode (2) photochemistry-Electrogenerated Chemiluminescence

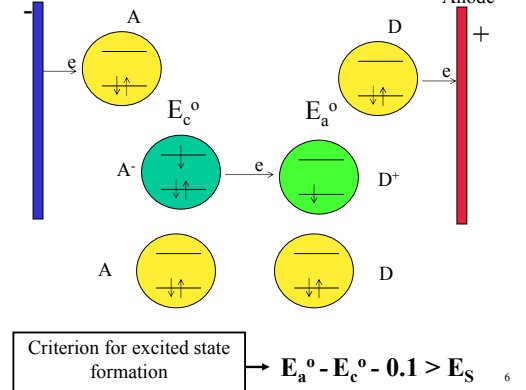

6

(2) photochemistry-Electrogenerated Chemiluminescence
b. Instrumentation

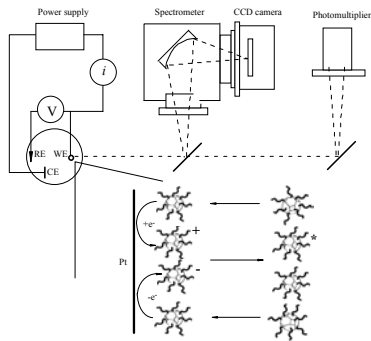

7

(2) photochemistry-Electrogenerated Chemiluminescence
c. Data Acquisition

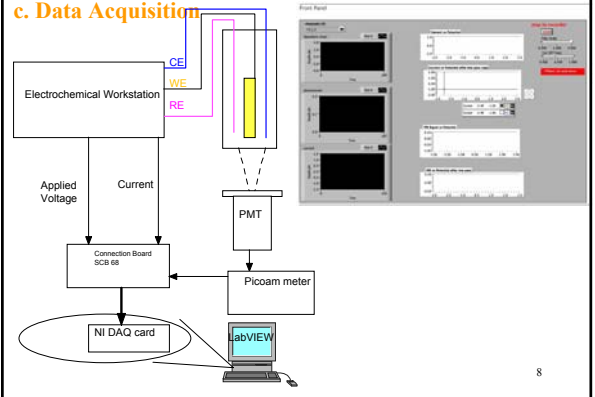

8

ECL_PMT610A.vi

Block Diagram

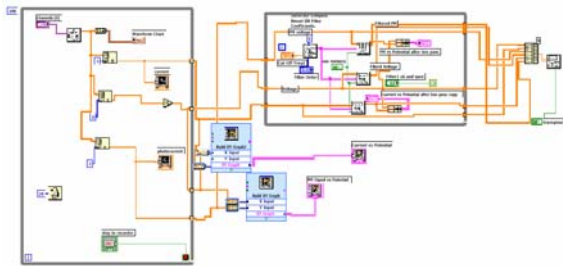

9

B. Scanning Probe Microscopy
Near-field Scanning Optical Microscopy (NSOM or SNOM)
a. principle

The diffraction limit in conventional microscopy
 (Abbe diffraction limit)

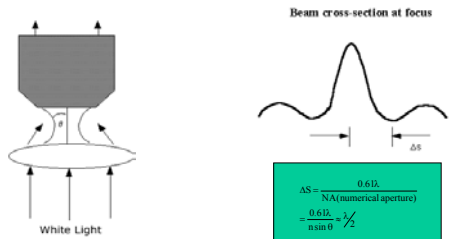

10

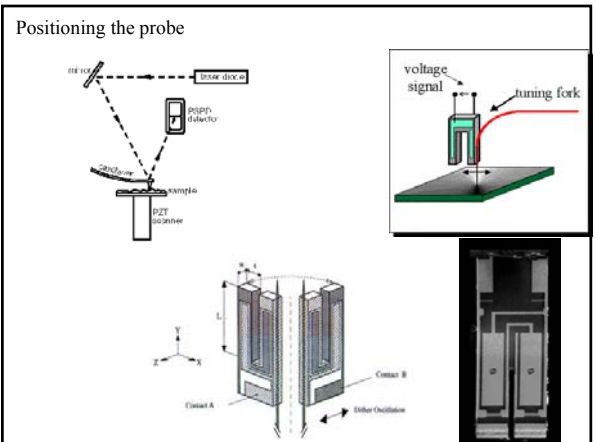
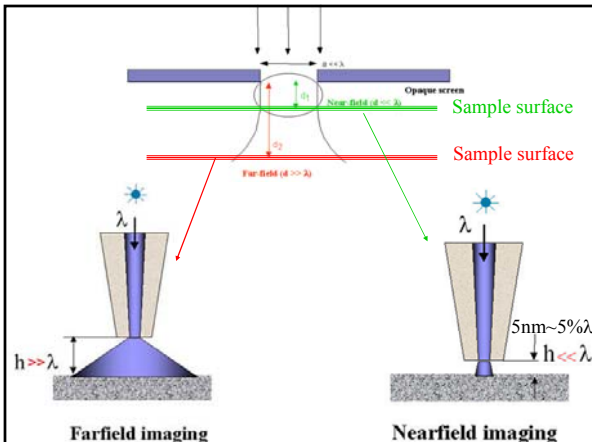

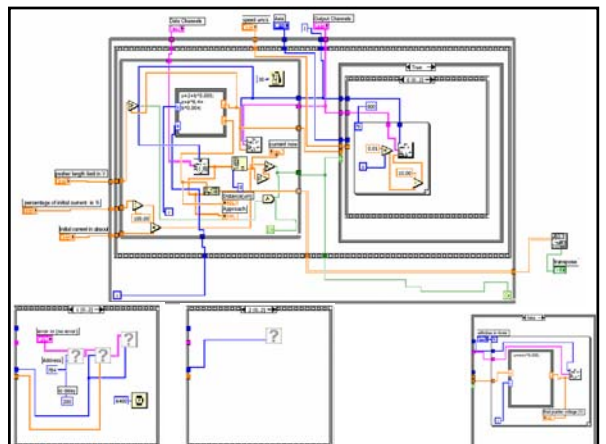
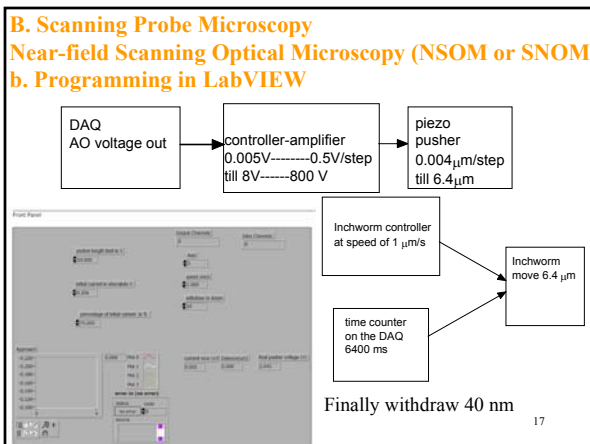
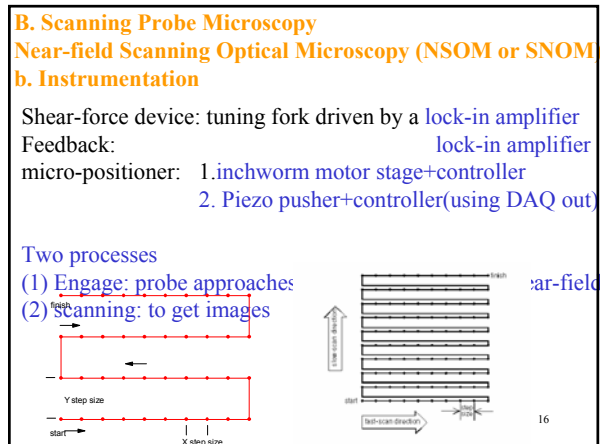
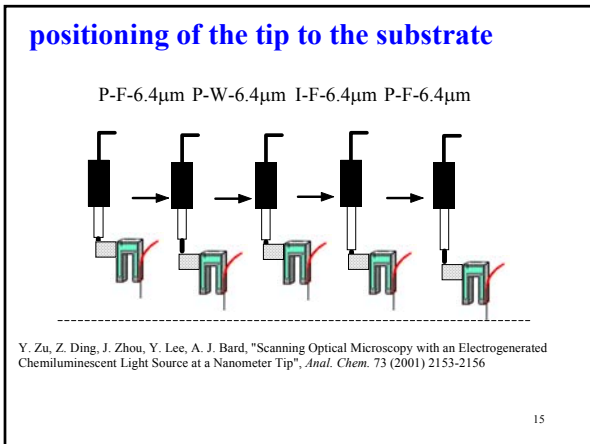
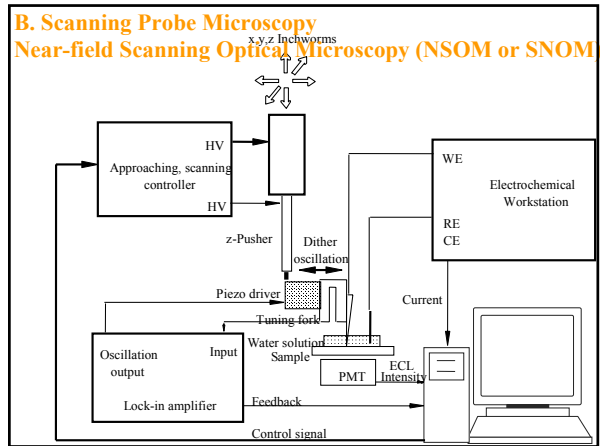
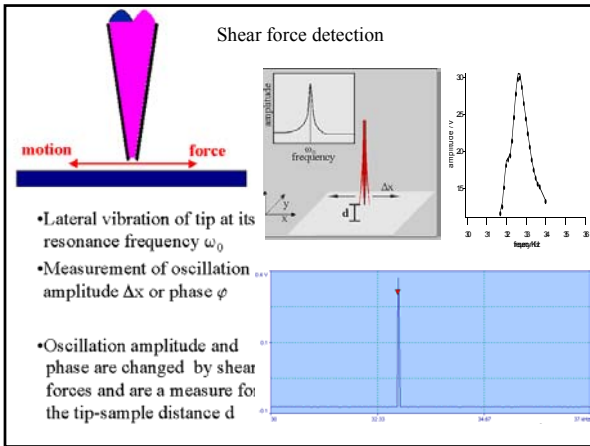

Let's play imag_demo.vi

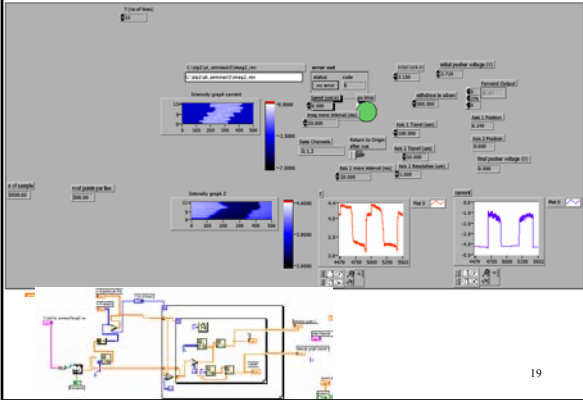

C. PID control in chemical engineering

In the PID (Proportional-Integral-Derivative) controller, the setpoint is compared to the process variable to obtain the error

$$e = SP - PV.$$

You can then calculate the controller action theoretically as

$$u(t) = K_c \left(e + \frac{1}{T_i} \int_0^t e dt + T_d \frac{de}{dt} \right),$$

where K_c is controller gain. If the error and the controller output have the same range, that is -100% to 100%, controller gain is the reciprocal of *proportional band*. T_i is the integral time in minutes (also called *reset time*), and T_d is the derivative time in minutes (also called *rate*). The proportional action is

$$u_p(t) = K_c e,$$

the integral action is

$$u_i(t) = \frac{K_c}{T_i} \int_0^t e dt,$$

and the derivative action is

$$u_d(t) = K_c T_d \frac{de}{dt}.$$

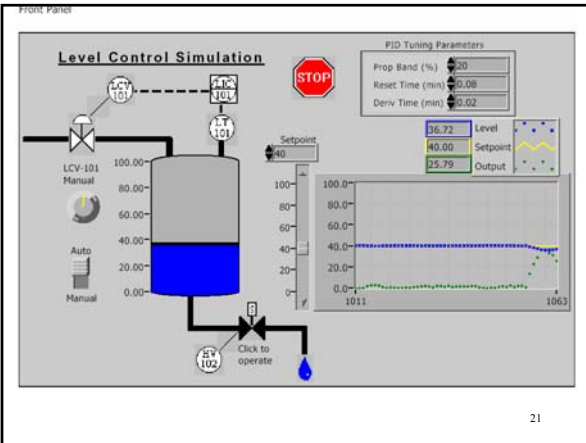

The Plant Simulator subVI, which simulates this process, reads and delays the previous valve position and scales it according to the process gain. The gain represents how fast the tank fills versus the position of the valve. The process load value depends on the state of HV-101, the drain valve. When you open the valve, the tank level drops.

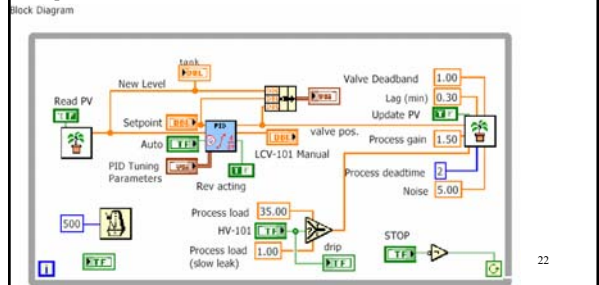

PID application to Scanning Probe Microscopy

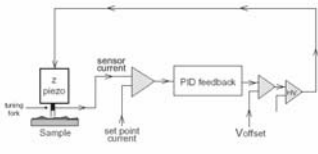

Figure 4-1. Feedback loop.

- Proportional gain responds quickly to small features but is not optimized to respond to large features.
- Integral gain controls the response time of the piezo to large, slow sensor changes. If set too high, integral gain can result in oscillation or noise in the image. This oscillation will be apparent on the oscilloscope signals.
- Derivative gain tends to reduce oscillation but may amplify high-frequency noise.

References

1. Z. F. Ding, R. G. Wellington, P. F. Brevet, H. H. Girault, "Spectroelectrochemical Studies of Ru(bpy)3(2+) at the Water/1,2-Dichloroethane Interface", *J. Phys. Chem.* 100 (1996) 10658-10663.
2. Z. Ding, B. M. Quinn, S. K. Haram, L. E. Pell, B. A. Korgel, A. J. Bard, "Electrochemistry and electrogenerated chemiluminescence from silicon nanocrystal quantum dots", *Science* 296 (2002) 1293-1297.
3. Y. Zu, Z. Ding, J. Zhou, Y. Lee, A. J. Bard, "Scanning Optical Microscopy with an Electrogenerated Chemiluminescent Light Source at a Nanometer Tip", *Anal. Chem.* 73 (2001) 2153-2156.

Summary



In-situ reaction monitoring, electrochemistry, spectroelectrochemistry can easily be done.